

**Thermo 90 S**

**Thermo 90 S-ADR**

(Transport of hazardous goods)

**Thermo 90 ST**

**Thermo 90 ST-ADR**

(Transport of hazardous goods)

---

**Table of contents**

<b>1</b>	<b>Introduction</b>	
1.1	Contents and purpose .....	101
1.2	Meaning of signal words .....	101
1.3	Additional documentation to be used .....	101
1.4	Safety instructions and regulations .....	101
	1.4.1 General safety regulations .....	101
1.5	Statutory regulations governing installation .....	102
1.6	Suggestions for improvements and modifications .....	102
<b>2</b>	<b>General description</b>	
2.1	Combustion air fan .....	202
2.2	Heat exchanger .....	202
2.3	Temperature sensor .....	203
2.4	Temperature limiter .....	203
2.5	Burner insert .....	203
2.6	Glow plug .....	203
2.7	Flame monitor .....	203
2.8	Combustion pipe .....	203
2.9	Circulating pump .....	203
2.10	Control unit .....	203
2.11	Metering pump .....	203
<b>3</b>	<b>Function description</b>	
3.1	Switching on .....	301
3.2	Heating mode .....	301
3.3	Control mode .....	301
3.4	Switching off .....	302
3.5	Heater functions when installed in ADR vehicles .....	302
3.6	Malfuctions .....	303
	3.6.1 Fault lock-out .....	303
	3.6.2 Diagnosis after fault lock-out, Thermo 90 S and Thermo 90 ST .....	304
<b>4</b>	<b>Technical data</b> .....	401
<b>5</b>	<b>Troubleshooting</b>	
5.1	General .....	501
5.2	General fault indications .....	501
5.3	Fault indications on fault lock-out .....	502
5.4	Visual check for assessing the burner .....	503
	5.4.1 Burner housing .....	503
	5.4.2 Back wall with metal evaporator .....	504
	5.4.3 Combustion chamber .....	504
	5.4.4 Complete burner .....	504

**6 Function tests**

6.1	General .....	601
6.2	Settings .....	601
6.2.1	Setting the CO <sub>2</sub> content .....	601
6.3	Testing individual components .....	601
6.3.1	Resistance test of the temperature sensor .....	601
6.3.2	Resistance test of the glow plug .....	601
6.3.3	Resistance test of the flame monitor .....	601
6.3.4	Testing the combustion air fan .....	601

**7 Circuit diagrams**

7.1	General .....	701
-----	---------------	-----

**8 Service work**

8.1	General .....	801
8.2	Work on the heater .....	801
8.3	Work on the vehicle .....	801
8.4	Heater trial run .....	802
8.5	Service work .....	802
8.6	Visual inspections and installation instructions .....	804
8.6.1	Connection to the vehicle cooling system .....	804
8.6.2	Connection to the vehicle fuel system .....	804
8.6.3	Metering pump with damper .....	807
8.6.4	Fuel filter .....	807
8.6.5	Combustion air supply .....	807
8.6.6	Exhaust line .....	808
8.7	Removal and installation .....	808
8.7.1	Heater, removal and installation .....	808
8.7.2	Changing the circulating pump .....	809
8.7.3	Changing the temperature limiter .....	809
8.7.4	Changing the temperature sensor .....	809
8.7.5	Changing the combustion air fan .....	809
8.8	Start-up .....	809

<b>9</b>	<b>Repair</b>	
9.1	General .....	901
9.1.1	Work on stripped-down components .....	901
9.2	Dismantling and assembling .....	902
9.2.1	Electrical connections (Thermo 90 S).....	902
9.2.2	Changing the circulating pump .....	903
9.2.3	Changing the temperature limiter .....	904
9.2.4	Changing the temperature sensor .....	904
9.2.5	Changing the combustion air fan.....	906
9.2.6	Changing the burner, flame monitor and glow plug.....	907
9.2.7	Changing the burner head.....	909
9.2.8	Changing the heat exchanger .....	910
<b>10</b>	<b>Packing, storage and shipment</b>	
10.1	General .....	1001

## List of illustrations

301	Sequence of functions .....	302
501	General fault indications .....	501
502	Fault indications on fault lock-out.....	502
503	Visual check, burner back wall.....	503
504	Visual check, pilot flame outlet opening.....	504
505	Visual check, complete burner.....	504
701	System circuit for Thermo 90 S, 12 and 24 V, with standard clock.....	702
702	System circuit for Thermo 90 S, 12 and 24 V, with standard clock and separate circulating pump control.....	703
703	System circuit for Thermo 90 S-ADR, 24 V, with switch .....	704
704	System circuit for Thermo 90 S-ADR, 24 V, with switch without power take-off.....	705
705	System circuit for Thermo 90 ST, 12 and 24 V, with standard digital timer .....	706
706	System circuit for Thermo 90 ST, 12 and 24 V, with standard digital timer and separate circulating pump control.....	707
707	System circuit for Thermo 90 ST-ADR, 24 V, with switch.....	708
708	System circuit for Thermo 90 ST-ADR, 24 V, with switch without power take-off.....	709
801	Specimen installations for heater in a truck .....	803
802	Fuel supply.....	804
803	Webasto fuel extractor .....	805
804	Fuel extraction from the plastic tank (extraction through tank drain screw).....	805
805	Fuel extraction from the plastic tank (extraction through tank fitting).....	805
806	Webasto fuel extractor .....	806
807	Pipe/hose connection.....	806
808	Metering pump, installation position and attachment .....	807
809	Exhaust pipe opening, installation position .....	808
901	Electrical connections (Thermo 90 S).....	902
902	Changing the circulating pump .....	903
903	Changing the temperature limiter and temperature sensor .....	905
904	Changing the combustion air fan .....	906
905	Changing the burner, flame monitor and glow plug .....	908
906	Changing the burner head .....	909

## 1 Introduction

### 1.1 Contents and purpose

This workshop manual is designed to assist trained personnel with repairing both the petrol and the diesel versions of the Thermo 90 S und Thermo 90 ST water heaters.

The heater is only allowed to be operated with the intended fuel (diesel or also with heating oil EL) and only in the particular prescribed electrical connection type.

### 1.2 Meaning of signal words

Throughout this manual, the signal words WARNING, CAUTION and NOTE have the following meanings:

#### **WARNING**

This heading is used to highlight operating instructions or procedures which, if not or not correctly followed, may result in personal injury or fatal accidents.

#### **CAUTION**

This heading is used to highlight operating instructions or procedures which, if not or not correctly followed, may result in damage to the equipment or its components.

#### **NOTE**

This heading is used to direct your attention to a special feature deemed essential to highlight.

### 1.3 Additional documentation to be used

This workshop manual contains all necessary information and instructions for repairing Thermo 90 S and Thermo 90 ST water heaters.

Normally, there is no need to use additional documentation.

If required, the installation instructions, the vehicle-specific installation instructions and the operating instructions can be used as well.

### 1.4 Safety instructions and regulations

In principle, the general accident prevention regulations and current works safety instructions are applicable. The "General safety regulations" that go beyond the scope of the above regulations are stated below.

Any special safety regulations relevant to this instruction manual will be highlighted in the relevant sections or text passages of the procedures.

#### 1.4.1 General safety regulations

**The year of first start-up must be indelibly identified on the rating plate by removing the corresponding year number.**

The heaters are only licensed for heating the motor vehicle engine and vehicle cabin, not however for heating the hazardous material transport space.

The heater is only allowed to be installed in motor vehicles or in independent heating systems with a minimum coolant volume of 6 litres.

The heater is not allowed to be installed in the driver's cab or passenger compartment of vehicles. If the heater is nevertheless installed in such a place, the installation box must be tightly sealed against the vehicle interior. The installation box must have sufficient external ventilation to ensure that a maximum temperature of 40 °C is not exceeded in the box. Malfunctions may occur if the temperature exceeds this level.

#### **WARNING**

**The heater must not be operated in enclosed areas, such as garages or workshops without an exhaust emissions extraction system, not even using the timer or Telestart, because of the risk of asphyxiation and poisoning.**

**The heater must be switched off at filling stations and fuel tank farms because of the risk of explosion.**

#### **CAUTION**

**Wherever inflammable vapours or dust may form (for example near fuel, coal, wood dust or cereal stores or the like), the heater must be switched off because of the risk of explosion.**

A temperature of 85 °C (storage temperature) must not be exceeded in the vicinity of the control unit (for example when completing painting work on the vehicle).

If this temperature is exceeded, the electronic systems may suffer permanent damage.

Follow the instructions supplied by the vehicle manufacturer to check the cooling water level. The water in the heating circuit of the heater must contain at least 10% branded anti-freeze.

Non-compliance with the installation instructions and the warnings contained therein will lead to the exclusion of all liability by Webasto. The same applies if repairs are carried out incorrectly or with the use of parts other than genuine spare parts. This will result in the revocation of the type licence for the heater and therefore the general operating licence for the vehicle.

**1.5 Statutory regulations governing installation**

Refer to the installation instructions for the statutory regulations if necessary.

**1.6 Suggestions for improvements and modifications**

Complaints, improvement suggestions or corrections relating to this technical manual should be addressed to:

Webasto Thermosysteme International GmbH  
Technical Documentation Dept.  
D-82131 Stockdorf  
Tel.: +49 (89) 8579 4542  
Fax: +49 (89) 8579 4757

**2 General description**

Thermo 90 S and Thermo 90 ST water heaters operate in conjunction with the vehicle's own heating system and serve

- to heat the cab,
- to defrost the vehicle windows and
- to preheat water-cooled engines.

The water heater operates independently of the engine and is connected to the cooling system, the fuel system and the electrical system of the vehicle.

The concept of the heater is based on the evaporator principle. It is controlled by the temperature sensor and operates intermittently.

Depending on the deviation between the current coolant temperature and the nominal value measured at the temperature sensor, the burner power is regulated between the limits of 1.8 to 7.6 kW in diesel heaters and 1.8 to 7.6 kW in petrol heaters. When the heating requirement is particularly high (preheating), diesel heaters provide a maximum power of 9.1 kW for up to

2 hours after the heater is switched on.

The Thermo 90 S and Thermo 90 ST heater is principally composed of

- the combustion air fan
- the heat exchanger
- the burner insert with combustion pipe
- the circulating pump

To control and monitor it, the heater has

- a control unit (external)
- a flame monitor
- a glow plug
- a temperature sensor
- a temperature limiter

inside it.

In the case of the Thermo 90 S heater, the control unit can also be flange-mounted on the combustion air fan.

The Thermo 90 ST heater is delivered with the control unit already flange-mounted on the combustion air fan.

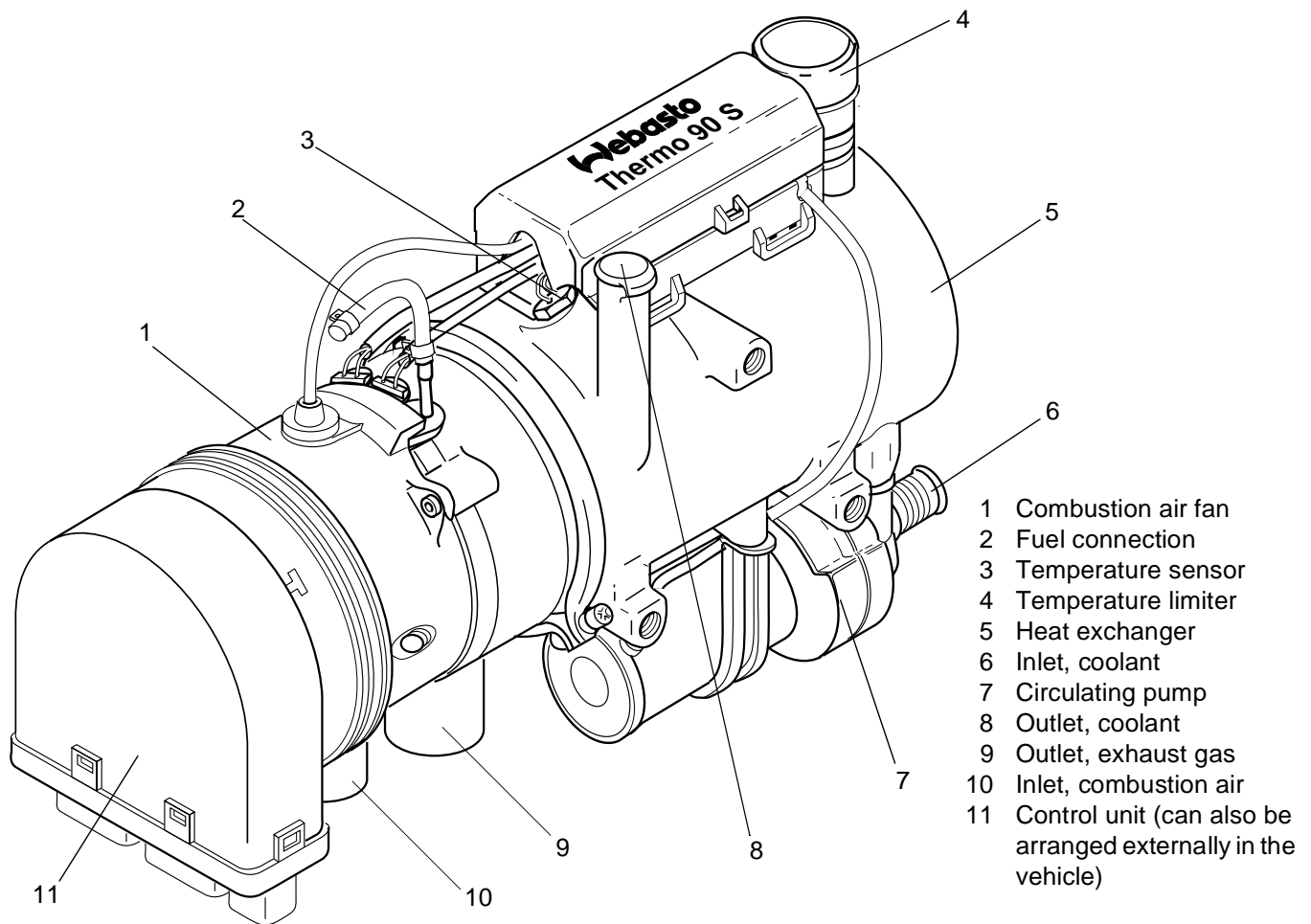

- 1 Combustion air fan
- 2 Fuel connection
- 3 Temperature sensor
- 4 Temperature limiter
- 5 Heat exchanger
- 6 Inlet, coolant
- 7 Circulating pump
- 8 Outlet, coolant
- 9 Outlet, exhaust gas
- 10 Inlet, combustion air
- 11 Control unit (can also be arranged externally in the vehicle)

Thermo 90 S heater

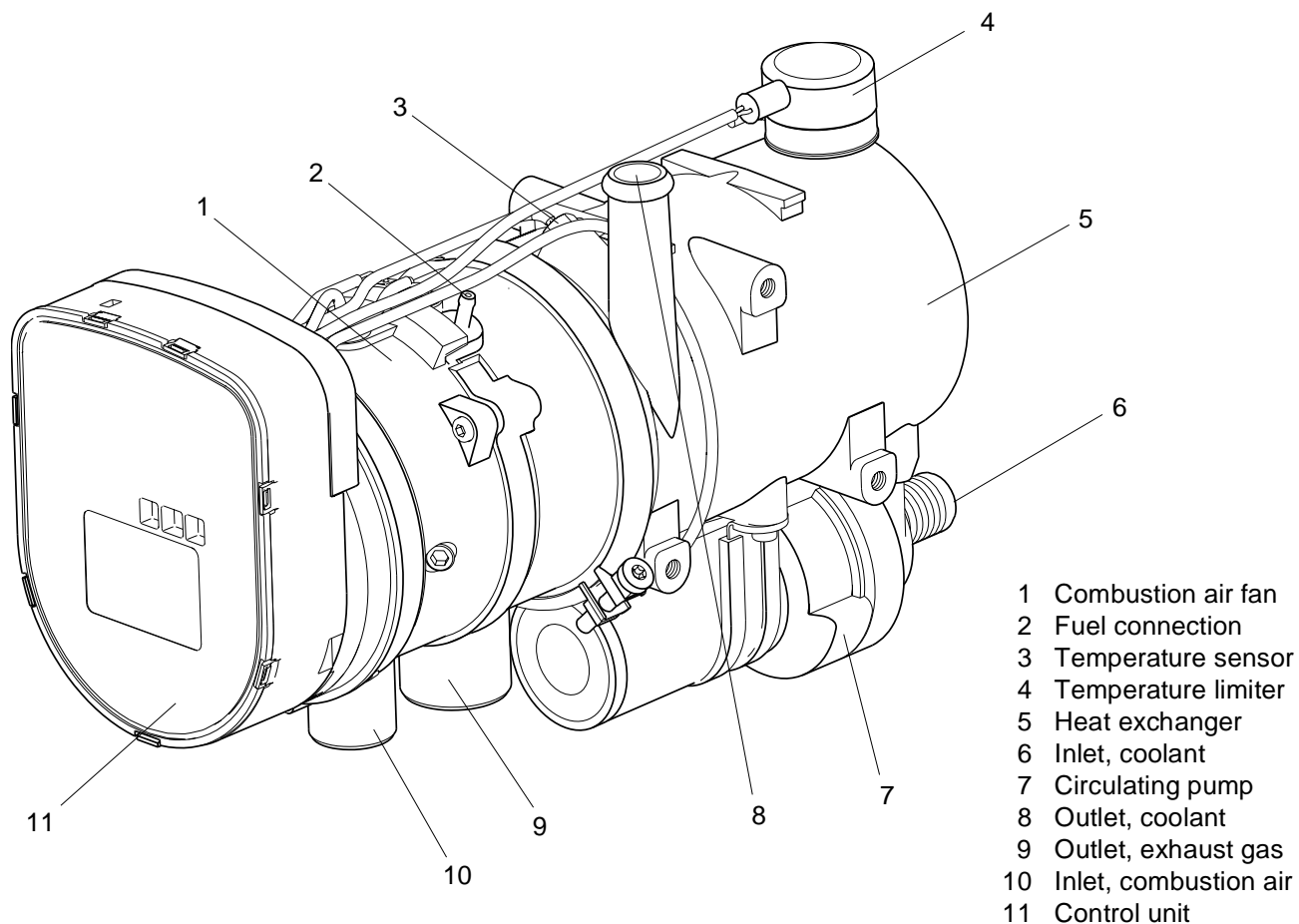

Thermo 90 ST heater

**2.1 Combustion air fan**

The combustion air fan supplies the air required for the combustion process from the combustion air inlet to the burner insert.

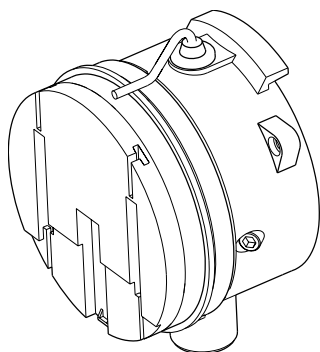

Combustion air fan

**2.2 Heat exchanger**

In the heat exchanger, the heat generated by combustion is transferred to the coolant circuit.

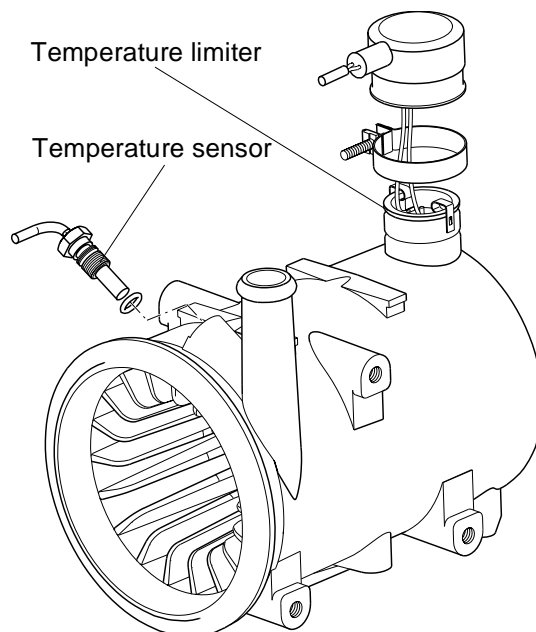

Heat exchanger

**2.3 Temperature sensor**

The temperature sensor records the coolant temperature at the coolant outlet of the heater as an electrical resistance. This signal is fed to the control unit where it is processed.

**2.4 Temperature limiter**

The overheating guard circuit (bimetallic) protects the heater against impermissibly high operating temperatures. The overheating guard circuit trips if the heat exchanger temperature exceeds  $127 \pm 7 \text{ }^\circ\text{C}$  and switches off the heater.

**2.5 Burner insert**

The fuel is distributed over the burner cross-section in the combustion pipe in the burner insert.

**2.6 Glow plug**

The mixture of fuel and air is ignited by the glow plug when the heater is started. The glow plug takes the form of an electrical resistor and is positioned in the burner insert on the side away from the flame.

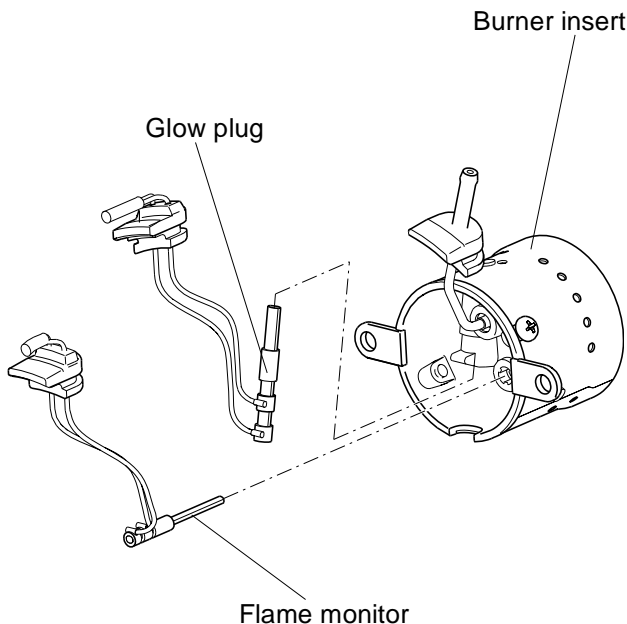

**2.7 Flame monitor**

The flame monitor is a low-ohm PTC resistor, which changes its resistance depending on the heat emitted by the flame. The signals are fed to the control unit where they are processed. The flame status is monitored by the flame monitor whenever the heater is operating.

**2.8 Combustion pipe**

The mixture of fuel and air burns in the combustion pipe, thus causing the heat exchanger to become hot.

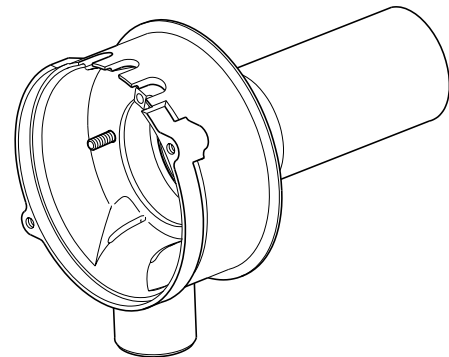

Combustion pipe

**2.9 Circulating pump**

The circulating pump ensures that coolant is pumped through the vehicle and heater circuits. The pump is switched on by the control unit and it runs throughout operation of the heater (including in the control pause).

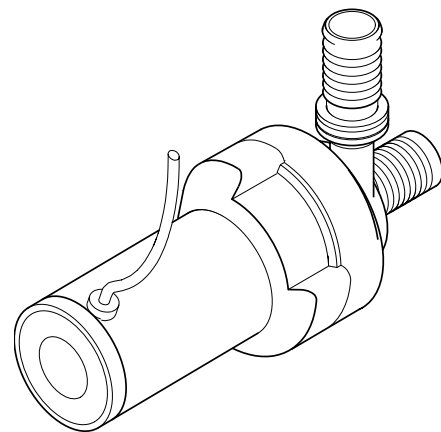

Circulating pump

**2.10 Control unit**

The control unit is the central component. It guarantees the sequence of functions and monitoring of combustion mode. It is flange-mounted on the combustion air fan, although in the case of the Thermo 90 S it may be installed externally in the vehicle.

**2.11 Metering pump**

The fuel supply and metering for the heater is assured by an external metering pump. In addition, it serves as a shut-off element when the heater is switched off. The solenoid coil of the metering pump receives its pulses from the microprocessor in the control unit.



### **3 Function description (Fig. 301)**

#### **3.1 Switching on**

The “operating indicator” on the digital timer lights up when the “immediate heating” button is pressed.

or

When switching on with the switch, the operating indicator in the switch lights up.

The circulating pump, glow plug and combustion air fan start operating.

#### **3.2 Heating mode**

Combustion starts after approx. 60 to 140 seconds. Automatically controlled heating operation runs at full load for a maximum of 2 hours.

The vehicle’s own heater fan does not switch on until the heat carrier (coolant) has heated up sufficiently. Once the preset nominal temperature has been reached (see table of regulating temperatures) the heating power is reduced to the lowest part load in small individual steps.

#### **3.3 Control mode**

The heater switches to the control pause if the temperature of the coolant continues to rise to the threshold of the control pause. The circulating pump, the vehicle’s own heater fan and the operating indicator continue to operate during the control pause. The heater restarts when the coolant cools to the preset temperature for switching back on.

##### **Diesel heaters**

If the water temperature in the heater is higher than the nominal temperature but has not yet reached the threshold for the control pause and if the temperature then falls back to the nominal temperature within 10 minutes (after reaching this temperature for the first time), the heater switches back to the 9.0 kW heating stage. When the nominal temperature is reached, the heater is only switched back on again up to the 7.6 kW heating stage.

##### **Petrol heaters**

The maximum heating power in petrol heaters is always 7.6 kW.

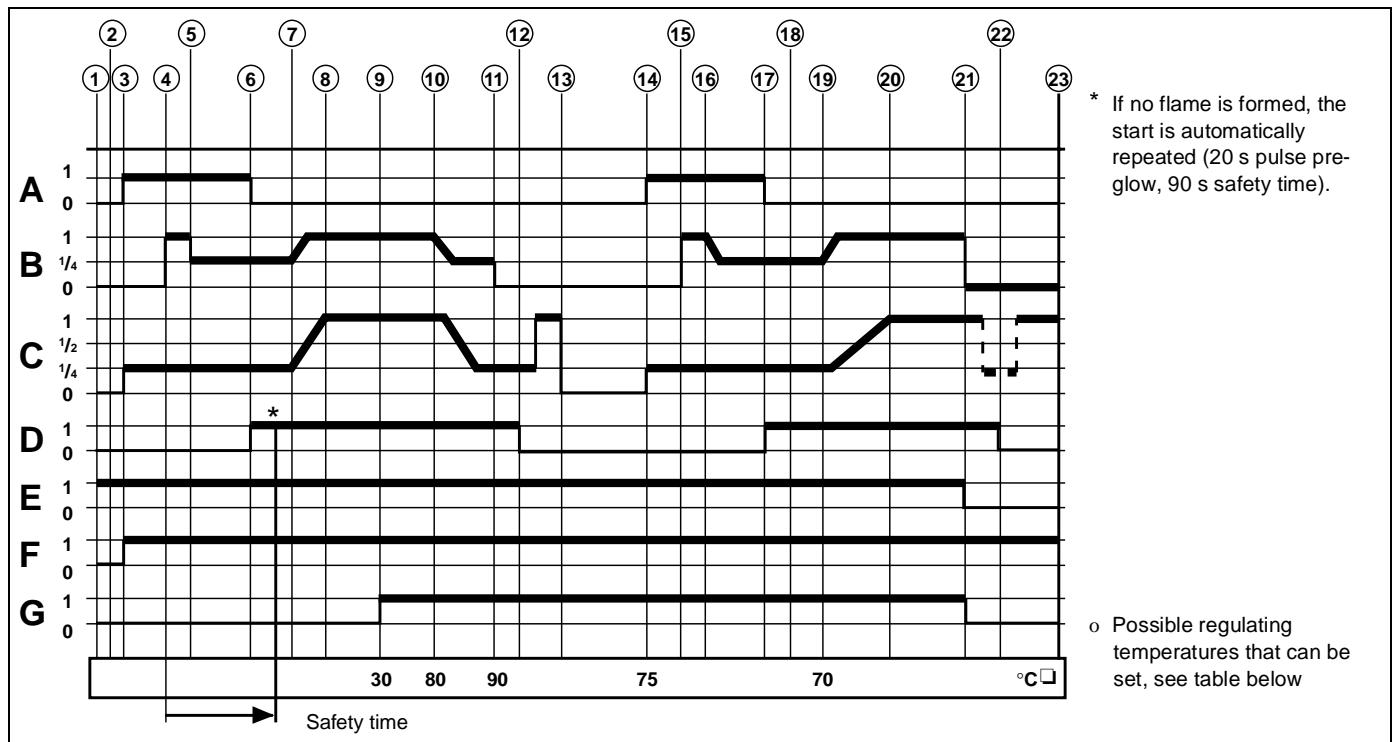

Fig. 301 Sequence of functions

### 3.4 Switching off

The operating indicator on the digital timer/switch goes out when the heater is switched off. The combustion process will be ended and the run-on phase will start. The circulating pump and the combustion air fan continue to run, however, in order to cool down the heater (run-on) and are switched off automatically after approx. 105 seconds. The heater may be switched on again during the run-on time.

The temperature in the cabin can also be controlled using the vehicle's own heater fan with a cabin thermostat.

### 3.5 Heater functions when installed in ADR vehicles

The heater is started using the switch. An ADR case (constrained shut-off) is triggered when

- the vehicle's engine is switched off,
- a pumping device is started,

in which case the short run-on is terminated after 20 seconds (Thermo 90 S) and after 40 seconds (Thermo 90 ST).

Following this, the control unit is left in the "fault lock-out" status. The on/off switch must be moved to "Off" before it can be restarted.

The disconnecting switch (emergency off switch) is only allowed to be used in case of danger, because the heater is switched off without any run-on (overheating possible).

### Sequence of functions for Thermo 90 S and ST

- |                                    |                                    |
|------------------------------------|------------------------------------|
| ① Switch on                        | ⑬ Run-on ended                     |
| ② Component interrogation          | ⑭ Pre-glow 15 – 20 s (pulsed)      |
| ③ Pre-glow 40 s (pulsed)           | ⑮ Metering pump supply 5 – 7 s (1) |
| ④ Metering pump supply 5 – 7 s (1) | ⑯ Metering pump / part load (1/4)  |
| ⑤ Metering pump / part load (1/4)  | ⑰ Flame monitor take-over          |
| ⑥ Flame monitor take-over          | ⑱ Stabilisation time               |
| ⑦ Stabilisation time               | ⑲ Coolant temperature reduced      |
| ⑧ Full load                        | ⑳ Full load                        |
| ⑨ Vehicle fan "On"                 | ㉑ Switch off (run-on)              |
| ⑩ Control range                    | ㉒ Flame monitor "Cold" (0)         |
| ⑪ Control pause                    | ㉓ Run-on ended                     |
| ⑫ Flame monitor "Cold" (0)         |                                    |

- A** Glow plug
- B** Metering pump
- C** Combustion air fan
- D** Flame monitor
- E** Operation indicator light
- F** Circulating pump
- G** Vehicle fan

**3.6 Malfunctions**

**3.6.1 Fault lock-out**

Fuel is supplied for max. 240 seconds if the flame does not start to burn.

Fuel is supplied for max. 240 seconds if the flame goes out during operation.

The fuel supply is shut off if the system overheats (temperature limiter is tripped). If the system overheats, the button on the temperature limiter must be reset.

Once the cause of the fault has been eliminated, the fault lock-out is cancelled by switching the heater off and on again.

If the undervoltage guard switches off the system

	Thermo 90 S and Thermo 90 ST
12 volts	10.5 V - 0.5 V
24 volts	21 V -1 V

for longer than 20 seconds, the fuel supply is interrupted.

**CAUTION**

A forced reset of the return spring when hot can result in damage to the component.

**3.6.2 Diagnosis after fault lock-out  
Thermo 90 S and Thermo 90 ST**

Check the fuses and plug connectors.

**3.6.2.1 Version with digital timer**

If the system is equipped with a standard clock, a fault message appears on the display of the digital timer after a fault occurs:

F 01	No start (after 2 attempts to start)
F 02	Flame failure
F 03	Undervoltage or overvoltage
F 04	Premature flame recognition
F 05	Flame monitor interrupt or flame monitor short circuit
F 06	Temperature sensor interrupt or temperature sensor short circuit
F 07	Metering pump interrupt or metering pump short circuit
F 08	Fan motor interrupt or fan motor short circuit or fan motor incorrect speed
F 09	Glow plug interrupt or glow plug short circuit
F 10	Overheating
F 11	Circulating pump interrupt or circulating pump short circuit

**3.6.2.2 Version with switch**

If the system is operated with a switch, the nature of the fault is indicated by a flashing code on an operating indicator light during the run-on time of the heater.

After five short signals, count the long flashes:

1x	No start (after 2 attempts to start)
2x	Flame failure
3x	Undervoltage or overvoltage
4x	Premature flame recognition
5x	Flame monitor interrupt or flame monitor short circuit
6x	Temperature sensor interrupt or temperature sensor short circuit
7x	Metering pump interrupt or metering pump short circuit
8x	Fan motor interrupt or fan motor short circuit or fan motor incorrect speed
9x	Glow plug interrupt or glow plug short circuit
10x	Overheating
11x	Circulating pump interrupt or circulating pump short circuit



4 Technical data

Except where limit values are specified, the technical data below refer to the usual heater tolerances of ±10% at an ambient temperature of +20 °C and at the rated voltage.

**Electrical components**

The control unit, motors for combustion air fan and circulating pump, glow plug, switch and digital timer (no timer for ADR mode) are designed for either 12 volts or 24 volts.

The temperature limiter, temperature sensor and flame monitor are identical on 12 V and 24 V heaters.

**Fuel for Thermo 90 S / Thermo 90 ST petrol:**

The fuel specified by the manufacturer must be used. Both leaded and unleaded fuel may be used.

**Fuel for Thermo 90 S / Thermo 90 ST and Thermo 90 S-ADR / Thermo 90 ST-ADR (diesel):**

The diesel fuel specified by the manufacturer must be used.

We know of no negative influences due to additives. If fuel is extracted from the vehicle's tank, follow the additive instructions issued by the vehicle manufacturer.

If you change to low-temperature fuel, the heater must be operated for approx. 15 minutes so that the fuel line and fuel pump are filled with the new fuel.

Heater	Operation	Thermo 90 S Petrol	Thermo 90 ST Petrol	Thermo 90 S diesel Thermo 90 S-ADR	Thermo 90 ST diesel Thermo 90 ST-ADR
EC licensing symbol		~S299		~S298	
Model		Water heater with Ferro-Tec technology			
Heat output	Max. regulating range	2.0 kW – 7.6 kW		9.1 kW 1.8 kW – 7.6 kW	
Fuel		Petrol		Diesel	
Fuel consumption	Max. regulating range	0.25 l/h – 1.0 l/h		1.1 l/h 0.19 l/h – 0.9 l/h	
Rated voltage		12 volts		12 or 24 volts	
Operating voltage range		10 ... 15 volts		10 ... 15 or 20 ... 30 volts	
Nominal power consumption with circulating pump (without vehicle fan)	Max. regulating range	37 W – 83 W		90 W 37 W – 83 W	
Max. ambient temperature: Heater: - Operation - Storage Control unit: - Operation - Storage Metering pump: - Operation - Storage Permitted operating pressure (heat carrier)	Max.	-40 ... +110 °C (90 °C with control unit installed on heater) -40 ... +110 °C (90 °C with control unit installed on heater) -40 ... +75 °C   -40 ... +85 °C   -40 ... +75 °C   -40 ... +85 °C -40 ... +85 °C -40 ... +20 °C   -40 ... +40 °C -40 ... +85 °C			
Capacity of the heat exchanger		0.15 l			
Max. combustion air intake temperature		+40 °C			
Minimum capacity of the circuit		6.00 l			
Delivery rate of the circulating pump against 0.15 bar		1650 l/h			
CO <sub>2</sub> in exhaust fumes (permitted function range)	Max.	10 ... 12.0% by volume			
CO <sub>2</sub> adjustment values at approx. +20 °C and geographic altitude above sea level	Max.	0 m 500 m 1000 m 10% 10.6% 11.3%			
Heater dimensions (tolerance ± 3 mm) * Control unit installed on the heater		L 310 (355*) mm W 131 mm H 232 mm	L 307 (352*) mm W 131 mm H 232 mm	L 310 (355*) mm W 131 mm H 232 mm	L 307 (352*) mm W 131 mm H 232 mm
Weight		4.8 kg			



## 5 Troubleshooting

### 5.1 General

This section describes how to identify and remedy faults on the Thermo 90 S und Thermo 90 ST heater.

**CAUTION**

Troubleshooting work demands precise knowledge of the structure and theory of operation of the various components and must be carried out by trained personnel only.

If in doubt, refer to sections 2 and 3 for a description of how the functions interact.

**CAUTION**

As a rule, fault detection is restricted to the localisation of defective components.

The following potential sources of malfunctions are not taken into account and should always be checked so that they can then be excluded as the cause of the particular fault:

- Corroded plugs
- Loose plug contacts
- Poor crimp contacts on plugs
- Corroded cables and fuses
- Corroded battery terminals
- Impermissibly high ambient temperature

Conduct a function test in the vehicle after rectifying each fault; switch the heater off and back on again first.

### 5.2 General fault indications

The following table (Fig. 501) lists the possible general fault indications.

Fault indication	Possible cause	Remedy
Heater switches off automatically	No combustion after start and restart	Control unit enters fault lock-out status. Switch the heater off and back on again.
	Flame extinguishes during operation	Contact a Webasto service centre if heater operation does not start again
	Heater overheats due to lack/ loss of coolant	Top up coolant. After the unit has cooled down, press the button of the temperature limiter before switching on or fit a new temperature limiter
	Voltage failure longer than 20 seconds	Check fuses, plug connectors and charge condition of the battery
	Switch off by temperature limiter	After the unit has cooled down, press the button of the temperature limiter before switching on or fit a new temperature limiter
	No flame recognition on start	Check flame monitor and connections

Fig. 501 General fault indications

**NOTE**

In many cases, the burner may be one possible cause. Perform a visual check in accordance with 5.4.

5.3 Fault indications on fault lock-out

**NOTE**

If the system is operated with a switch, the nature of the fault is indicated by a flashing code on an indicator light during the run-on time of the heater.

After five short signals, count the long flashes.

In the Thermo 90 S heater with a standard clock, the fault is output on the clock display (see 3.6.3). The following table can be used accordingly.

Fault indication	Possible cause	Remedy
No function	Electrical cabling, fuses	Check fuses Check battery connections: + on 12 / - on 9 / + on 3, plug X12 (Thermo 90 S) + on 12 / - on 9 / + on 3, plug X8 (Thermo 90 ST)
	Control unit defective	Replace control unit
1 Flashing pulse (start did not occur)	Fuel system	Check fuel level Check fuel filter Bleed fuel system
	Combustion air/exhaust line	Check combustion air/exhaust line for foreign bodies and clean if necessary
	Burner	Clean burner and change if necessary
2 Flashing pulses (flame failure during burner operation)	Fuel supply	Check fuel level Check fuel filter Bleed fuel system
	Burner	Clean burner and change if necessary
3 Flashing pulses (undervoltage)	Electrical power supply	Check battery Check electrical connections
4 Flashing pulses (flame monitor continuously hot)	Flame monitor defective	Replace flame monitor
5 Flashing pulses (flame monitor defective)	Cabling	Check cabling for damage, discontinuity and short-circuit
	Flame monitor defective	Replace flame monitor
6 Flashing pulses (temperature sensor defective)	Cabling	Check cabling for damage, discontinuity and short-circuit
	Temperature sensor defective	Replace temperature sensor
7 Flashing pulses (metering pump defective/overheating guard circuit defective)	Coolant circuit	Check coolant level Bleed coolant circuit Reset temperature limiter
	Cabling	Check cabling for damage, discontinuity and short-circuit
	Metering pump defective	Replace metering pump
8 Flashing pulses (combustion air fan defective)	Cabling	Check cabling for damage, discontinuity and short-circuit
	Combustion air fan defective	Replace combustion air fan

Fig. 502 Fault indications on fault lock-out (page 1 of 2)

Fault indication	Possible cause	Remedy
9 Flashing pulses (glow plug defective)	Cabling	Check cabling for damage, discontinuity and short-circuit
	Flow plug defective	Replace glow plug
10 Flashing pulses (overheating)	Heater overheats	Check coolant and top up if necessary. After the unit has cooled down, press the button of the temperature limiter before switching on or fit a new temperature limiter
11 Flashing pulses (circulating pump defective)	Cabling	Check cabling for damage, discontinuity and short-circuit
	Circulating pump defective	Replace circulating pump

Fig. 502 Fault indications on fault lock-out (page 2 of 2)

### 5.4 Visual check for assessing the burner

The burner and the evaporator in the heater display specific characteristics when they must be replaced or do not have any fault source.

The criteria of a correct check are listed below.

#### 5.4.1 Burner housing

- The start air hole (Fig. 503) must be clear otherwise no start will occur.

**Remedy**

Carefully remove impurities from the start air hole (e.g. using a 1.5 mm diameter wire). Remove the glow plug first.

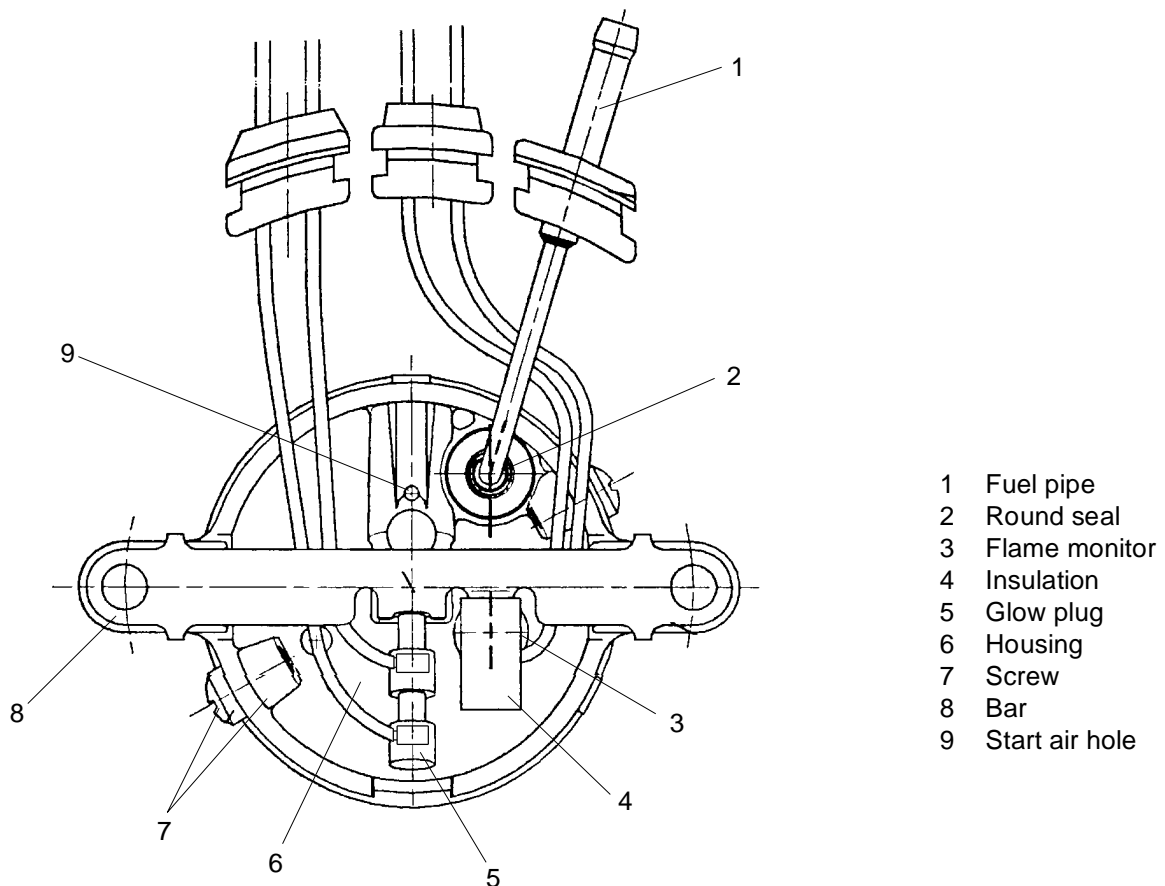

Fig. 503 Visual check, burner back wall

## 5.4.2 Back wall with metal evaporator

- The pilot flame outlet opening (Fig. 504) must be clear otherwise no start will occur.

**Remedy**

Replace burner

- Cracks, flaking as well as black or other discoloration of the evaporator do not lead to burner failure and are not significant.
- Coke deposits on the evaporator surface (except for the pilot flame outlet opening) are normal; as a rule, the burner cleans itself due to the load changes from full load to part load and part load to full load.

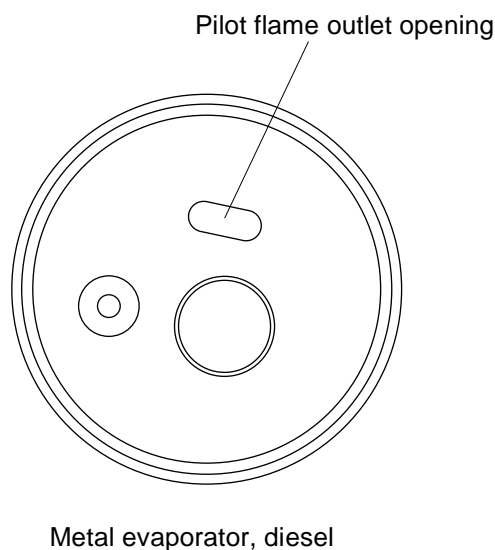
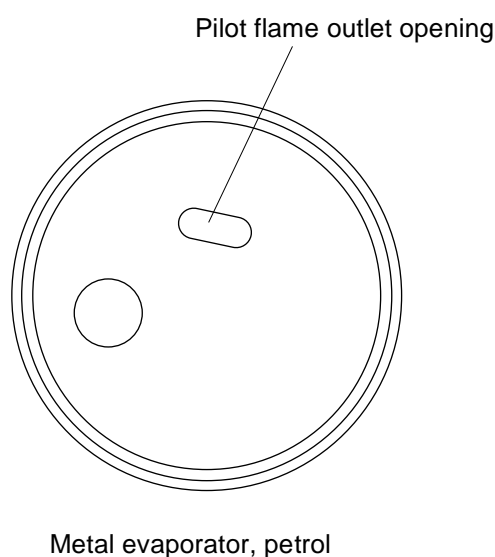

Fig. 504 Visual check, pilot flame outlet opening

## 5.4.3 Combustion chamber

- The combustion chamber (Fig. 505) should not be damaged (e.g. dented). A dented combustion chamber can lead to poor combustion or carbon build-up in the heater.

**Remedy**

Replace burner

- The air holes (Fig. 505) in the combustion chamber must not be blocked up by carbon deposits. If the air holes are blocked up by carbon deposits, this may result in failure of combustion to start or to run effectively.

**Remedy**

Carefully scratch clear the air holes

## 5.4.4 Complete burner

- The cables of the glow plug and flame monitor must be routed as shown in Fig. 503.
- The screw connection of the housing and combustion chamber (Fig. 505) must be tight.
- The housing and the combustion chamber (Fig. 505) must be firmly connected together and there must not be any play (check by moving the fuel pipe slightly).
- The round sealing ring (Fig. 503) must evenly surround the fuel pipe and must not leak.
- The distance (gap) between the edge of the housing and the top edge of the combustion chamber (Fig. 505) does not have to be even all the way around.
- The insulation (Fig. 503) must not be missing.

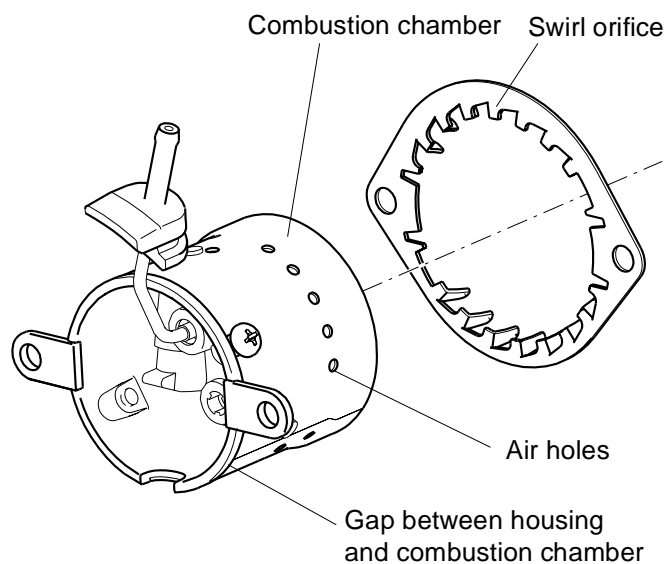

Fig. 505 Visual check, complete burner

## 6 Function tests

### 6.1 General

This section describes the tests conducted on the heater and its settings when it is installed and not installed to verify that it is in working order.

**WARNING**

The heater must not be operated in enclosed areas such as garages and workshops without an emissions extraction system.

### 6.2 Settings

#### 6.2.1 Setting the CO<sub>2</sub> content

It is permitted for the factory-set combustion air quantity to be modified. This is achieved by turning the air regulating screw.

**Setting procedure**

*Turning clockwise:* CO<sub>2</sub> value is reduced (let the heater run for about 5 minutes before measuring).

*Rough setting:* Screw the adjusting screw fully in clockwise and then one turn back.

### 6.3 Testing individual components

#### 6.3.1 Resistance test of the temperature sensor

If you conduct this electrical test with a digital multimeter, the temperature sensor should have the following values at room temperature:

Resistance at 25 °C: 990 ... 1010 Ω  
 Test current: < 1 mA

#### 6.3.2 Resistance test of the glow plug

If you conduct this electrical test with a digital multimeter, the glow plug should have the following values:

Glow plug:	12 volts (red)	24 volts
(green)		
Resistance at 25 °C:	0.3 ... 0.6 Ω	1.3 ... 1.44 Ω
Test current:	< 5 mA	< 5 mA

#### 6.3.3 Resistance test on the flame monitor

If you conduct this electrical test with a digital multimeter, the flame monitor should have the following values:

<i>Cold test:</i>	
Resistance at 25 °C:	3.0 ±0.4 Ω
Test current:	< 5 mA
<i>Hot test:</i>	
Resistance at 800 ±20 °C:	8 ±1.0 Ω
(ceramic rod at red heat over length of approx. 20 mm)	
Test current:	< 5 mA

#### 6.3.4 Testing the combustion air fan

The motor speed test must be performed with the heater assembled and in the operating voltage range. Listen out for grinding noises.

**NOTE**

The cover must be removed from the fan in order to check the motor speed. Fit a new seal before re-installing.

**CAUTION**

Make sure the detent lugs do not break off. Fit a new cover and a new seal if the detent lugs have broken off.

Speed in control range min.	1800 rpm	(±9%)
Speed in control range max.	5600 rpm	(±9%)

Fit a new combustion air fan if the speeds are outside tolerance (see 9.2.5).



## **7 Circuit diagrams**

### **7.1 General**

The circuit diagrams (Figs. 701 to 704) show the possible circuits for the Thermo 90 S heater with

- Standard clock
- Standard clock and separate circulating pump control
- ADR and switch
- ADR and switch, without power take-off

The circuit diagrams (Figs. 705 to 708) show the possible circuits for the Thermo 90 ST heater with

- Standard clock
- Standard clock and separate circulating pump control
- ADR and switch
- ADR and switch, without power take-off

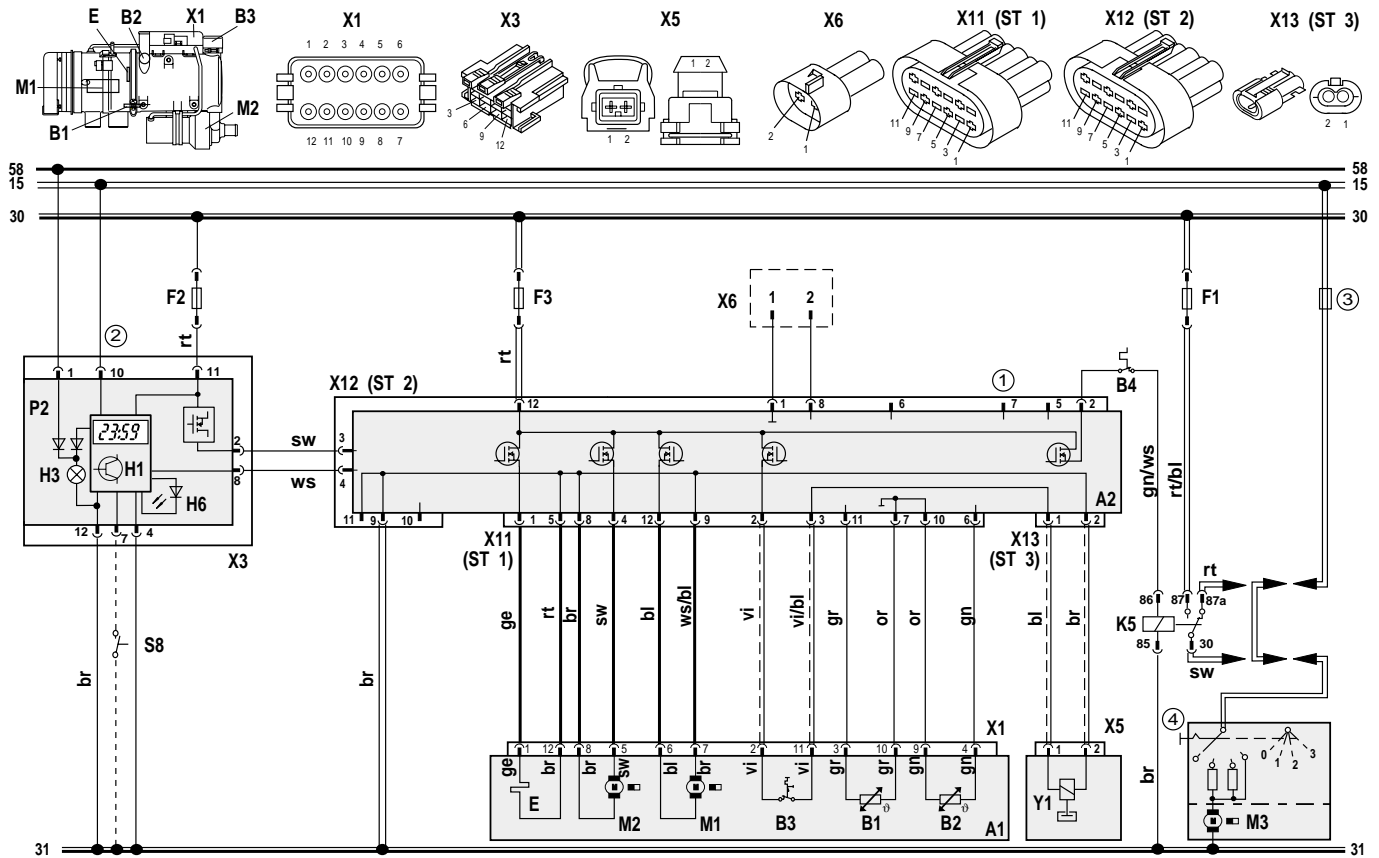

- ① Temperature coding (temperature at water outlet):  
See table on page 302
- ② Digital timer P2:  
with positive at connection 10 = Continuous operation with immediate heating  
Connection 10 open = Variable heating duration can be (10 min to 120 min);  
Default setting 120 min
- ③ Vehicle fuse
- ④ Vehicle fan switch

Cable cross-sections		
	< 7.5 m	7.5 - 15 m
—	0.75 mm <sup>2</sup>	1.0 mm <sup>2</sup>
- - -	0.75 mm <sup>2</sup>	1.0 mm <sup>2</sup>
— — —	1.0 mm <sup>2</sup>	1.5 mm <sup>2</sup>
— — — —	1.5 mm <sup>2</sup>	2.5 mm <sup>2</sup>
— — — — —	2.5 mm <sup>2</sup>	4.0 mm <sup>2</sup>
— — — — — —	4.0 mm <sup>2</sup>	6.0 mm <sup>2</sup>

Cable colours	
bl	Blue
br	Brown
ge	Yellow
gn	Green
gr	Grey
or	Orange
rt	Red
sw	Black
vi	Violet
ws	White

Item	Designation	Comment
A1	Heater	
A2	Control unit	
B1	Flame monitor	
B2	Temperature sensor	
B3	Temperature limiter/ overheating guard circuit	
B4	Cabin thermostat	
E	Glow plug	
F1	20 A fuse	Blade-type fuse SAE J 1284
F2	5 A fuse	Blade-type fuse SAE J 1284
F3	20 A fuse	Blade-type fuse SAE J 1284
H1	"Heating" symbol in the display	Operating indicator (in item P2)
H3	Symbol light	Light (in item P2)
H6	Red LED	Light in immediate heat button, ready indicator, switch-on indicator (in item P2)
K5	Relay	For vehicle fan
M1	Motor	Combustion air fan

Item	Designation	Comment
M2	Motor	Circulating pump
M3	Motor	Vehicle fan
P2	Standard clock	For programmed operation
S8	Momentary-contact switch	Immediate heat button remote control
X1	12-pin plug connector	To item A1
X3	12-pin plug connector	To item P2
X5	2-pin plug connector	To Y1
X6	2-pin plug connector	Diagnosis
X11	12-pin plug connector	To item A2 (ST 1)
X12	12-pin plug connector	To item A2 (ST 2)
X13	2-pin plug connector	To item A2 (ST 3)
Y1	Metering pump	Fuel pump for heater

Fig. 701 System circuit for Thermo 90 S, 12 and 24 V, with standard clock

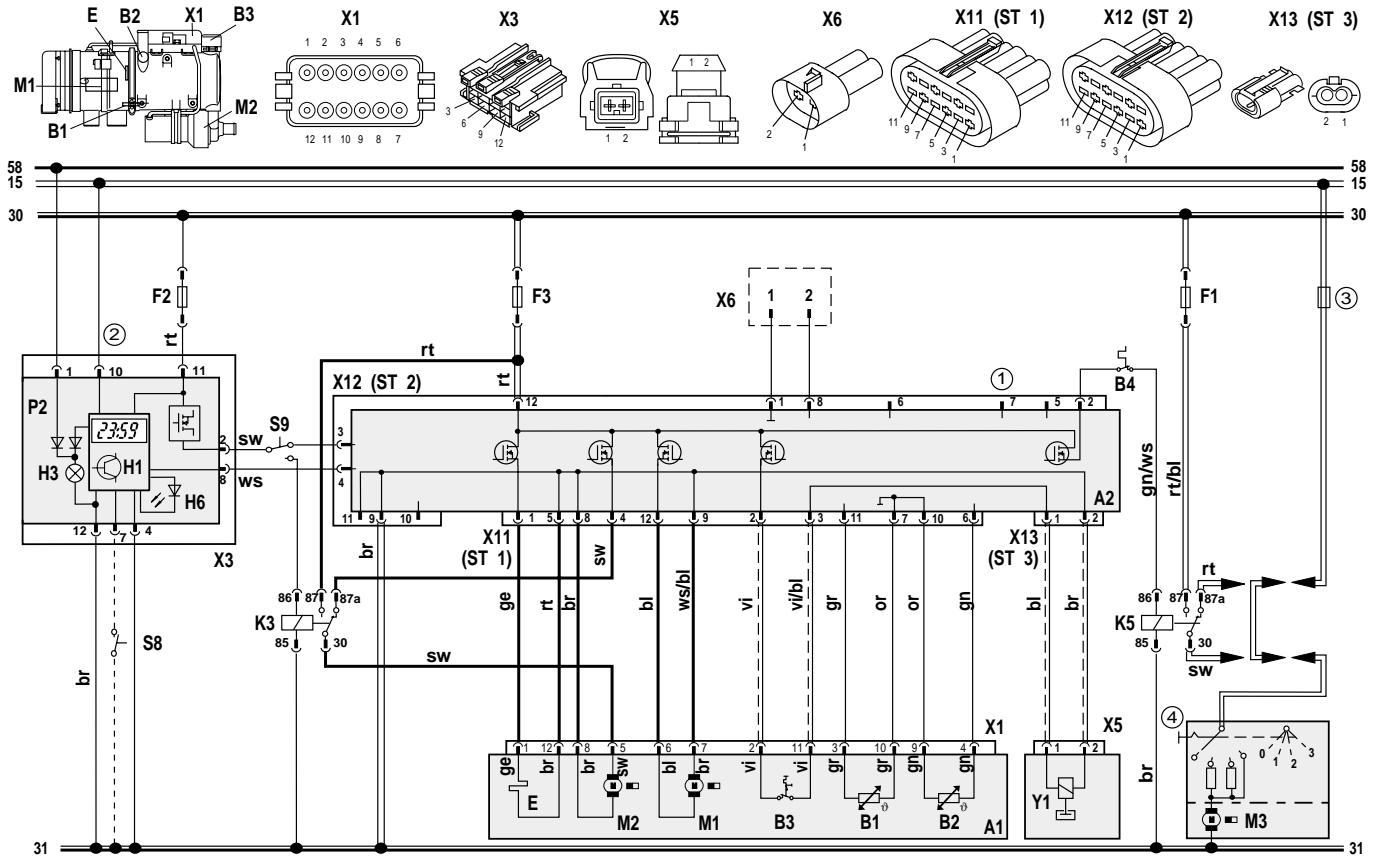

- ① Temperature coding (temperature at water outlet):  
See table on page 302
- ② Digital timer P2:  
with positive at connection 10 = Continuous operation with immediate heating  
Connection 10 open = Variable heating duration can be (10 min to 120 min); Default setting 120 min
- ③ Vehicle fuse
- ④ Vehicle fan switch

Cable cross-sections		
	< 7.5 m	7.5 - 15 m
———	0.75 mm <sup>2</sup>	1.0 mm <sup>2</sup>
- - - -	0.75 mm <sup>2</sup>	1.0 mm <sup>2</sup>
— · — ·	1.0 mm <sup>2</sup>	1.5 mm <sup>2</sup>
———	1.5 mm <sup>2</sup>	2.5 mm <sup>2</sup>
———	2.5 mm <sup>2</sup>	4.0 mm <sup>2</sup>
———	4.0 mm <sup>2</sup>	6.0 mm <sup>2</sup>

Cable colours	
bl	Blue
br	Brown
ge	Yellow
gn	Green
gr	Grey
or	Orange
rt	Red
sw	Black
vi	Violet
ws	White

Item	Designation	Comment
A1	Heater	
A2	Control unit	
B1	Flame monitor	
B2	Temperature sensor	
B3	Temperature limiter/overheating guard circuit	
B4	Cabin thermostat	
E	Glow plug	
F1	20 A fuse	Blade-type fuse SAE J 1284
F2	5 A fuse	Blade-type fuse SAE J 1284
F3	20 A fuse	Blade-type fuse SAE J 1284
H1	"Heating" symbol in the display	Operating indicator (in item P2)
H3	Symbol light	Light (in item P2)
H6	Red LED	Light in immediate heat button, ready indicator, switch-on indicator (in item P2)
K3	Relay	For circulating pump remote control
K5	Relay	For vehicle fan

Item	Designation	Comment
M1	Motor	Combustion air fan
M2	Motor	Circulating pump
M3	Motor	Vehicle fan
P2	Standard clock	For programmed operation
S8	Momentary-contact switch	Immediate heat button remote control
S9	Switch	Heating/circulating pump remote control
X1	12-pin plug connector	To item A1
X3	12-pin plug connector	To item P2
X5	2-pin plug connector	To Y1
X6	2-pin plug connector	Diagnosis
X11	12-pin plug connector	To item A2 (ST 1)
X12	12-pin plug connector	To item A2 (ST 2)
X13	2-pin plug connector	To item A2 (ST 3)
Y1	Metering pump	Fuel pump for heater

Fig. 702 System circuit for Thermo 90 S, 12 and 24 V, with standard clock and separate circulating pump control

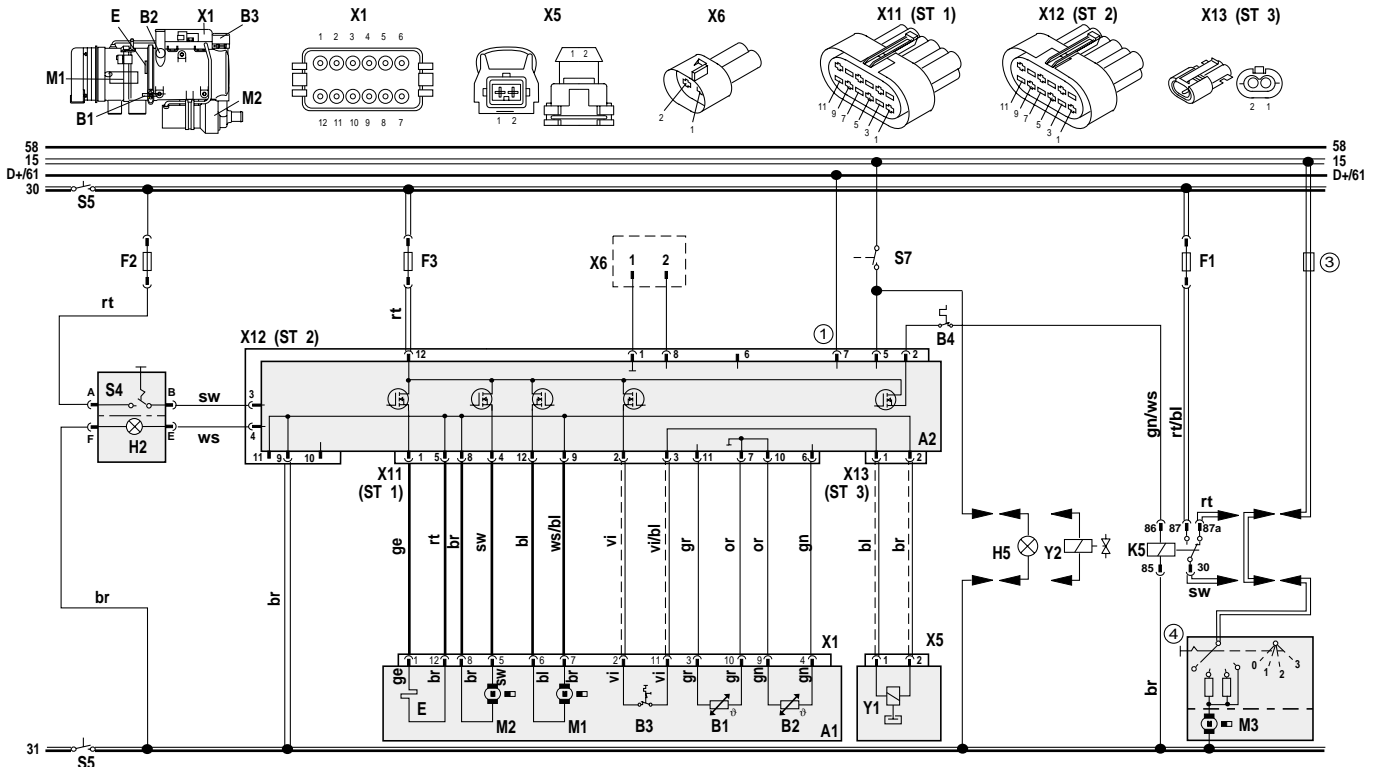

- ① Temperature coding (temperature at water outlet):  
See table on page 302
- ③ Vehicle fuse
- ④ Vehicle fan switch

Cable cross-sections		
	< 7.5 m	7.5 - 15 m
	0.75 mm <sup>2</sup>	1.0 mm <sup>2</sup>
	0.75 mm <sup>2</sup>	1.0 mm <sup>2</sup>
	1.0 mm <sup>2</sup>	1.5 mm <sup>2</sup>
	1.5 mm <sup>2</sup>	2.5 mm <sup>2</sup>
	2.5 mm <sup>2</sup>	4.0 mm <sup>2</sup>
	4.0 mm <sup>2</sup>	6.0 mm <sup>2</sup>

Cable colours	
bl	Blue
br	Brown
ge	Yellow
gn	Green
gr	Grey
or	Orange
rt	Red
sw	Black
vi	Violet
ws	White

Item	Designation	Comment
A1	Heater	
A2	Control unit	
B1	Flame monitor	
B2	Temperature sensor	
B3	Temperature limiter/ overheating guard circuit	
B4	Cabin thermostat	
E	Glow plug	
F1	20 A fuse	Blade-type fuse SAE J 1284
F2	5 A fuse	Blade-type fuse SAE J 1284
F3	20 A fuse	Blade-type fuse SAE J 1284
H2	Light max. 2 W	Operating indicator (in item S4)
H5	Lamp min. 1.2 W	Switch-on indicator pumping device
K5	Relay	For vehicle fan
M1	Motor	Combustion air fan
M2	Motor	Circulating pump
M3	Motor	Vehicle fan
S4	Switch	ON/OFF

Item	Designation	Comment
S5	1 or 2-pin disconnecting switch	Emergency off switch electrical or pneumatic
S7	Pumping device switch	To positive
X1	12-pin plug connector	To item A1
X5	2-pin plug connector	To Y1
X6	2-pin plug connector	Diagnosis
X11	12-pin plug connector	To item A2 (ST 1)
X12	12-pin plug connector	To item A2 (ST 2)
X13	2-pin plug connector	To item A2 (ST 3)
Y1	Metering pump	Fuel pump for heater
Y2	Solenoid valve	For pumping device

Fig. 703 System circuit for Thermo 90 S-ADR, 24 V, with switch



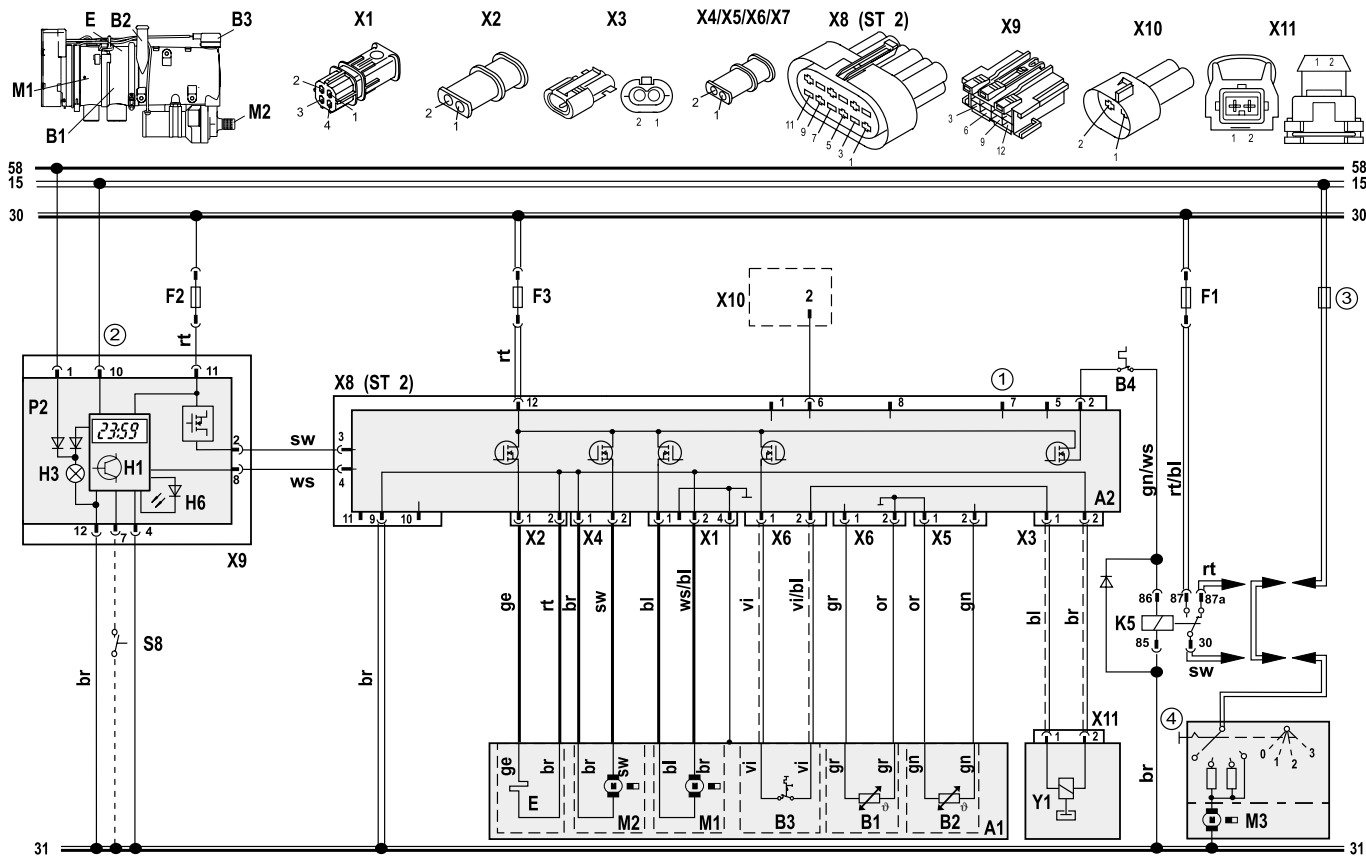

- ① Temperature coding (temperature at water outlet): See table on page 302
- ② Digital timer P2:  
with positive at connection 10 = Continuous operation with immediate heating  
Connection 10 open = Variable heating duration can be programmed (10 min to 120 min); Default setting 120 min
- ③ Vehicle fuse
- ④ Vehicle fan switch

Cable cross-sections		
	< 7.5 m	7.5 - 15 m
—	0.75 mm <sup>2</sup>	1.0 mm <sup>2</sup>
- - -	0.75 mm <sup>2</sup>	1.0 mm <sup>2</sup>
— — —	1.0 mm <sup>2</sup>	1.5 mm <sup>2</sup>
— — — —	1.5 mm <sup>2</sup>	2.5 mm <sup>2</sup>
— — — — —	2.5 mm <sup>2</sup>	4.0 mm <sup>2</sup>
— — — — — —	4.0 mm <sup>2</sup>	6.0 mm <sup>2</sup>

Cable colours	
bl	Blue
br	Brown
ge	Yellow
gn	Green
gr	Grey
or	Orange
rt	Red
sw	Black
vi	Violet
ws	White

Item	Designation	Comment
A1	Heater	
A2	Control unit	
B1	Flame monitor	
B2	Temperature sensor	
B3	Temperature limiter/overheating guard circuit	
B4	Cabin thermostat	
E	Glow plug	
F1	20 A fuse	Blade-type fuse SAE J 1284
F2	5 A fuse	Blade-type fuse SAE J 1284
F3	20 A fuse	Blade-type fuse SAE J 1284
H1	"Heating" symbol in the display	Operating indicator (in item P2)
H3	Symbol light	Light (in item P2)
H6	Red LED	Light in immediate heat button, ready indicator, switch-on indicator (in item P2)
K5	Relay	For vehicle fan
M1	Motor	Combustion air fan
M2	Motor	Circulating pump
M3	Motor	Vehicle fan

Item	Designation	Comment
P2	Standard clock	For programmed operation
S8	Momentary-contact switch	Immediate heat button remote control
X1	4-pin plug connector	To item A2
X2	2-pin plug connector	To item A2
X3	2-pin plug connector	To item A2
X4	2-pin plug connector	To item A2
X5	2-pin plug connector	To item A2
X6	2-pin plug connector	Diagnosis
X8	12-pin plug connector	To item A2 (ST 2)
X9	12-pin plug connector	To item P2
X10	2-pin plug connector	W-bus diagnosis
X11	2-pin plug connector	To Y1
Y1	Metering pump	Fuel pump for heater

Fig. 705 System circuit for Thermo 90 ST, 12 and 24 V, with standard clock

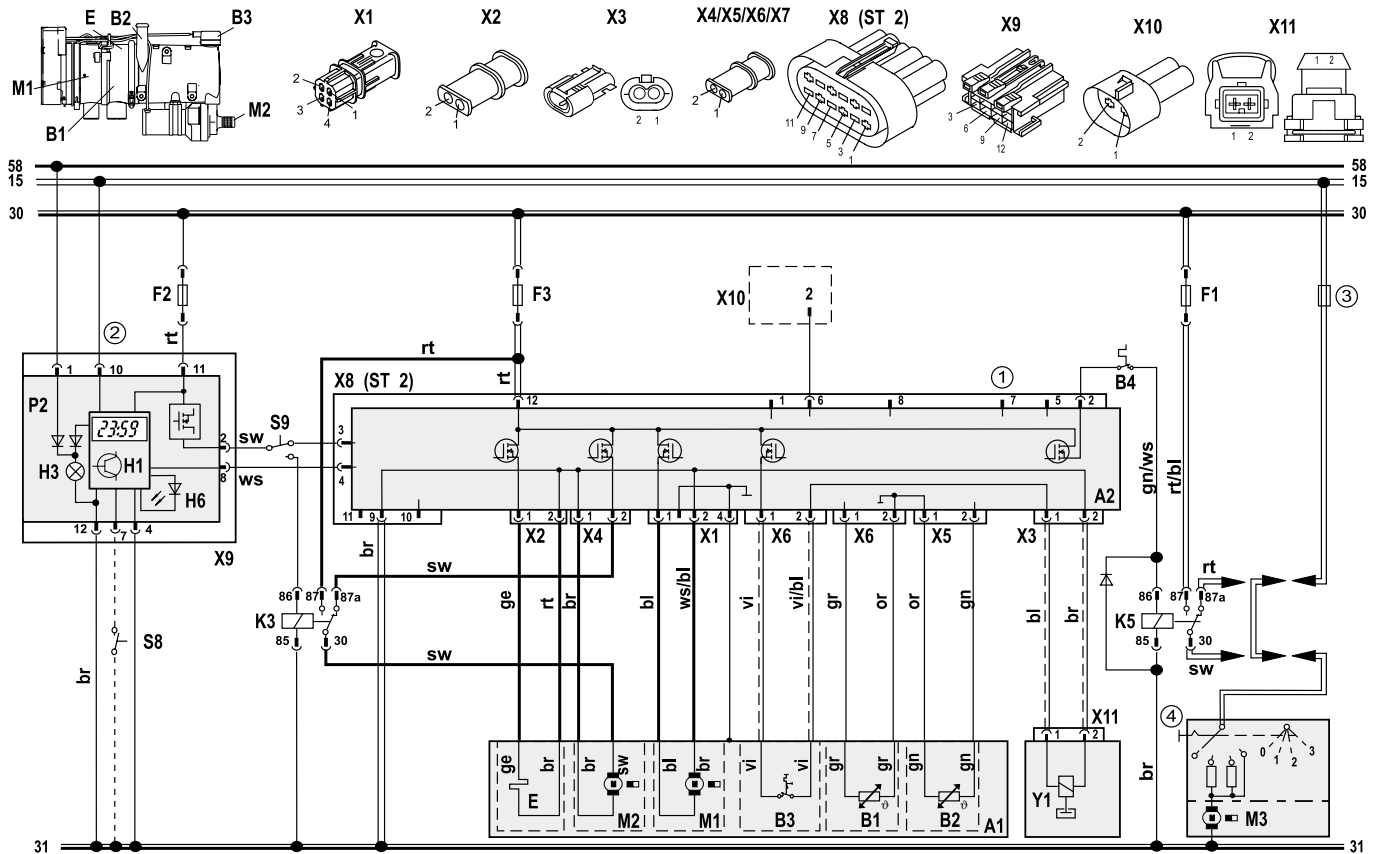

- ① Temperature coding (temperature at water outlet):  
See table on page 302
- ② Digital timer P2:  
with positive at connection 10 = Continuous operation with immediate heating  
Connection 10 open = Variable heating duration can be programmed (10 min to 120 min);  
Default setting 120 min
- ③ Vehicle fuse
- ④ Vehicle fan switch

Cable cross-sections		
	< 7.5 m	7.5 - 15 m
—	0.75 mm <sup>2</sup>	1.0 mm <sup>2</sup>
- - -	0.75 mm <sup>2</sup>	1.0 mm <sup>2</sup>
— — —	1.0 mm <sup>2</sup>	1.5 mm <sup>2</sup>
— — — —	1.5 mm <sup>2</sup>	2.5 mm <sup>2</sup>
— — — — —	2.5 mm <sup>2</sup>	4.0 mm <sup>2</sup>
— — — — — —	4.0 mm <sup>2</sup>	6.0 mm <sup>2</sup>

Cable colours	
bl	Blue
br	Brown
ge	Yellow
gn	Green
gr	Grey
or	Orange
rt	Red
sw	Black
vi	Violet
ws	White

Item	Designation	Comment
A1	Heater	
A2	Control unit	
B1	Flame monitor	
B2	Temperature sensor	
B3	Temperature limiter/overheating guard circuit	
B4	Cabin thermostat	
E	Glow plug	
F1	20 A fuse	Blade-type fuse SAE J 1284
F2	5 A fuse	Blade-type fuse SAE J 1284
F3	20 A fuse	Blade-type fuse SAE J 1284
H1	"Heating" symbol in the display	Operating indicator (in item P2)
H3	Symbol light	Light (in item P2)
H6	Red LED	Light in immediate heat button, ready indicator, switch-on indicator (in item P2)
K3	Relay	For circulating pump remote control
K5	Relay	For vehicle fan

Item	Designation	Comment
M1	Motor	Combustion air fan
M2	Motor	Circulating pump
M3	Motor	Vehicle fan
P2	Standard clock	For programmed operation
S8	Momentary-contact switch	Immediate heat button remote control
S9	Switch	Heating/circulating pump remote control
X1	4-pin plug connector	To item A2
X2	2-pin plug connector	To item A2
X3	2-pin plug connector	To item A2
X4	2-pin plug connector	To item A2
X5	2-pin plug connector	To item A2
X6	2-pin plug connector	Diagnosis
X8	12-pin plug connector	To item A2 (ST 2)
X9	12-pin plug connector	To item P2
X10	2-pin plug connector	W-bus diagnosis
X11	2-pin plug connector	To Y1
Y1	Metering pump	Fuel pump for heater

Fig. 706 System circuit for Thermo 90 ST, 12 and 24 V, with standard clock and separate circulating pump control

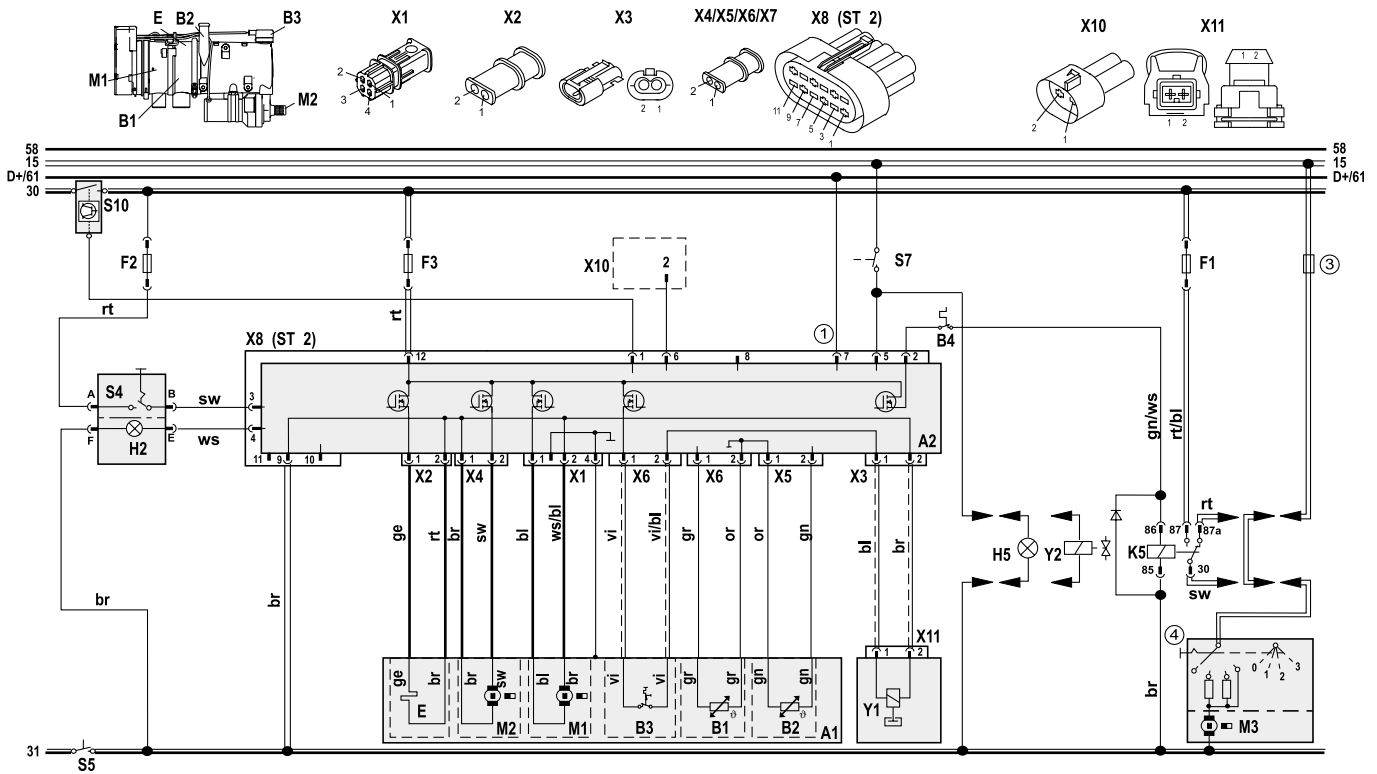

- ① Temperature coding (temperature at water outlet):  
See table on page 302
- ③ Vehicle fuse
- ④ Vehicle fan switch

Cable cross-sections		
	< 7.5 m	7.5 - 15 m
—	0.75 mm <sup>2</sup>	1.0 mm <sup>2</sup>
- - -	0.75 mm <sup>2</sup>	1.0 mm <sup>2</sup>
— — —	1.0 mm <sup>2</sup>	1.5 mm <sup>2</sup>
— — — —	1.5 mm <sup>2</sup>	2.5 mm <sup>2</sup>
— — — — —	2.5 mm <sup>2</sup>	4.0 mm <sup>2</sup>
— — — — — —	4.0 mm <sup>2</sup>	6.0 mm <sup>2</sup>

Cable colours	
bl	Blue
br	Brown
ge	Yellow
gn	Green
gr	Grey
or	Orange
rt	Red
sw	Black
vi	Violet
ws	White

Item	Designation	Comment
A1	Heater	
A2	Control unit	
B1	Flame monitor	
B2	Temperature sensor	
B3	Temperature limiter/ overheating guard circuit	
B4	Cabin thermostat	
E	Glow plug	
F1	20 A fuse	Blade-type fuse SAE J 1284
F2	5 A fuse	Blade-type fuse SAE J 1284
F3	20 A fuse	Blade-type fuse SAE J 1284
H2	Light max. 2 W	Operating indicator (in item S4)
H5	Lamp min. 1.2 W	Switch-on indicator pumping device
K5	Relay	For vehicle fan
M1	Motor	Combustion air fan
M2	Motor	Circulating pump
M3	Motor	Vehicle fan
S4	Switch	ON/OFF

Item	Designation	Comment
S5	1 or 2-pin disconnecting switch	Emergency off switch electrical or pneumatic
S7	Pumping device switch	To positive
S10	Switch	Battery switch in positive
X1	4-pin plug connector	To item A2
X2	2-pin plug connector	To item A2
X3	2-pin plug connector	To item A2
X4	2-pin plug connector	To item A2
X5	2-pin plug connector	To item A2
X6	2-pin plug connector	Diagnosis
X8	12-pin plug connector	To item A2 (ST 2)
X10	2-pin plug connector	W-bus diagnosis
X11	2-pin plug connector	To Y1
Y1	Metering pump	Fuel pump for heater
Y2	Solenoid valve	For pumping device

Fig. 707 System circuit for Thermo 90 ST-ADR, 24 V, with switch





## **8 Service work**

### **8.1 General**

This section describes the service work that can be carried out on the heater when it is installed.

### **8.2 Work on the heater**

Disconnect the main power cable from the vehicle's battery before carrying out any work on the heater. The main battery power must not be disconnected whilst the heater is operating or running on as a result of the risk of the heater overheating and the overheating guard circuit thus being tripped.

If you wish to carry out extensive repair work on the heater, it may be a good idea to remove it completely. After working on the heating circuit, top up with a coolant mixture of water and antifreeze according to the manufacturer's instructions and carefully bleed the heating circuit.

Refer to the relevant installation instructions and the installation proposal for the heater for the specific vehicle for repairs that necessitate the installation position being changed.

### **8.3 Work on the vehicle**

#### **CAUTION**

A temperature of 90 °C must not be exceeded in the vicinity of the heater in any circumstances (for example when completing painting work on the vehicle). See section 4.

**8.4 Heater trial run**

The heater must not be operated in enclosed areas such as garages and workshops without an emissions extraction system, even if you use the timer.

**8.5 Service work**

The following service work is to be carried out after or before each heating period to maintain the functional reliability of the heater:

- Clean the exterior of the heater (avoid the ingress of water).
- Check the electrical connections for contact corrosion and to ensure that they are secure.
- Check the exhaust and combustion air lines for signs of damage and to ensure that they are clear.
- Check the fuel line and filter for leaks.
- Check the coolant circuit and circulating pump for leaks.
- Inspect hoses for cracks.
- Replace the fuel filter if there is one.

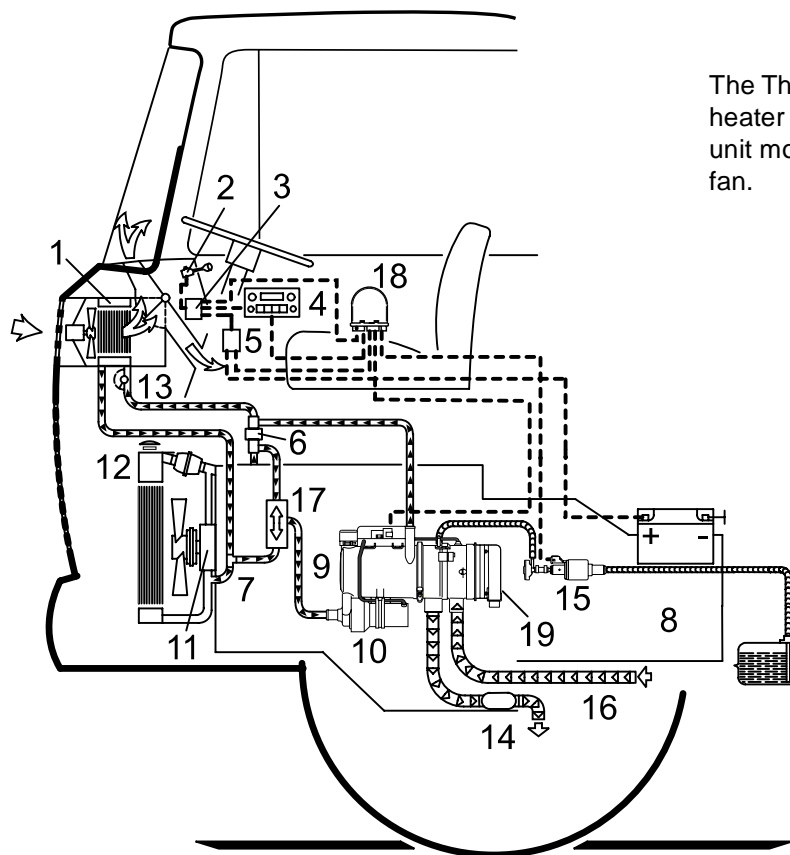

With non-return valve and thermostat

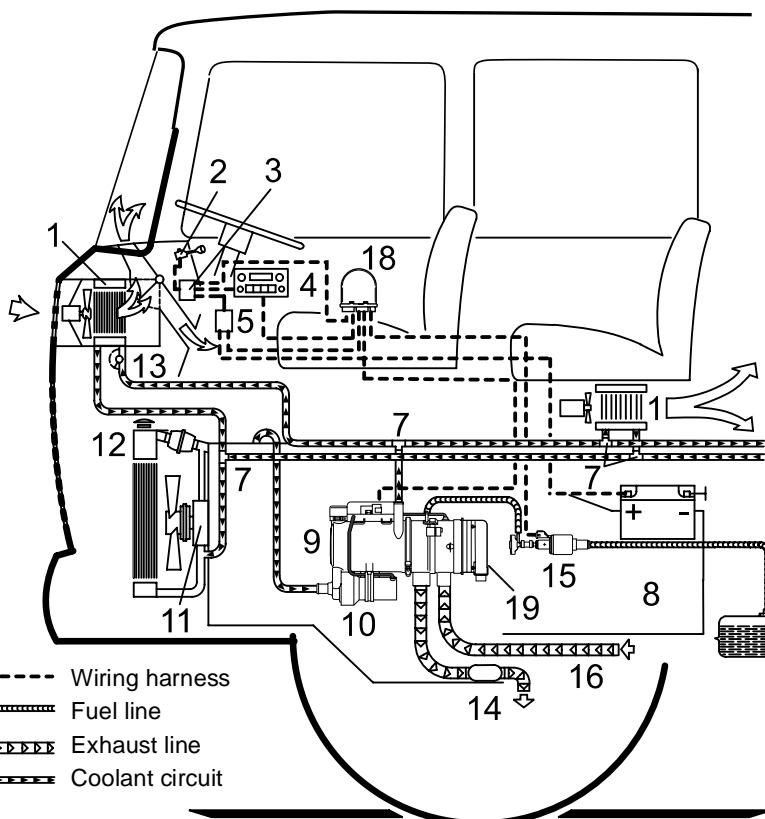

Without non-return valve

**NOTE**

The Thermo 90 S and Thermo 90 ST heater is supplied with the control unit mounted on the combustion air fan.

- 1 Heat exchanger vehicle heating
- 2 Switch for fan of the vehicle heating
- 3 Relay for vehicle fan
- 4 Digital timer
- 5 Fuse strip in the car
- 6 Non-return valve with leakage hole
- 7 T-piece
- 8 Vehicle engine
- 9 Heater
- 10 Circulating pump
- 11 Water pump
- 12 Radiator
- 13 Regulating valve
- 14 Exhaust muffler
- 15 Metering pump
- 16 Combustion air intake line
- 17 Thermostat
- 18 Control unit (optional on the Thermo 90 S)
- 19 Control unit (installation position of Thermo 90 ST and optionally in Thermo 90 S)

Fig. 801 Specimen installations for heater in a truck

8.6 Visual inspections and installation instructions

8.6.1 Connection to the vehicle cooling system

In thermostat circuits, only use thermostats which start to open at < 65 °C.

The heater should be installed in as low a position as possible to allow the heater and circulating pump to be bled automatically.

This is particularly important as the circulating pump is not self-priming.

The heater is connected to the vehicle cooling system as shown in Fig. 801. The system must contain at least 6 litres of coolant.

The coolant hoses supplied by Webasto must always be used. If you do not use these hoses, the hoses that you do use must comply with DIN 73411. The hoses must be installed without kinks and (to ensure perfect bleeding) rising if possible.

Hose connections must be supported by hose clips to prevent them slipping.

**NOTE**

The hose clips must be tightened with a torque of 4 Nm.

The cooling system must be bled carefully before using the heater for the first time or after replacing the coolant. The heater and lines should be installed in such a way as to ensure static bleeding.

Perfect ventilation can be identified by the circulating pump operating almost silently. Poor bleeding may cause the resetting temperature limiter to trip whilst the heater is operating.

8.6.2 Connection to the vehicle fuel system

The fuel is taken from the vehicle fuel tank or from a separate fuel tank.

The values for the maximum pressure at the fuel extraction point are shown in the table below.

Permissible fuel inflow height H (m)	At max. pressure (bar) in fuel line
0.00	0.20
1.00	0.11
2.00	0.03
Maximum fuel intake height S (m)	At max. negative pressure (bar) in fuel tank
0.00	-0.10
0.50	-0.06
1.00	-0.02

Only for ADR: The statutory regulation of ADR (Accord européen relatif au transport international des marchandises dangereuses par route) governing fuel tanks, part 9 para. 9.2.4.7, must be adhered to.

**NOTE**

A sign must be affixed to the fuel filler neck warning that the heater must be switched off before refuelling.

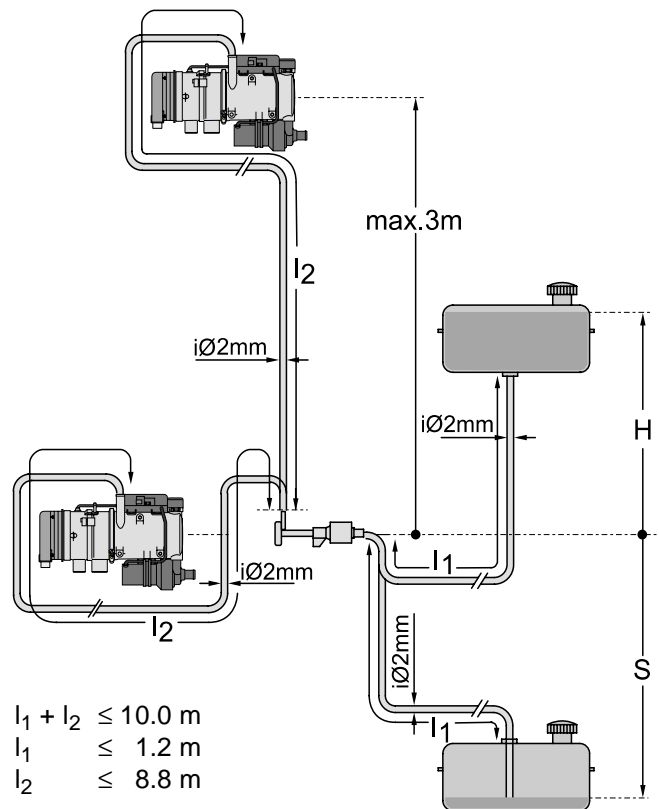

$$\begin{aligned}
 l_1 + l_2 &\leq 10.0 \text{ m} \\
 l_1 &\leq 1.2 \text{ m} \\
 l_2 &\leq 8.8 \text{ m}
 \end{aligned}$$

Fig. 802 Fuel supply

8.6.2.1 Fuel extraction

Vehicles with diesel engines

The fuel must be taken from the vehicle fuel tank or from a separate tank (Figs. 803, 804 and 805).

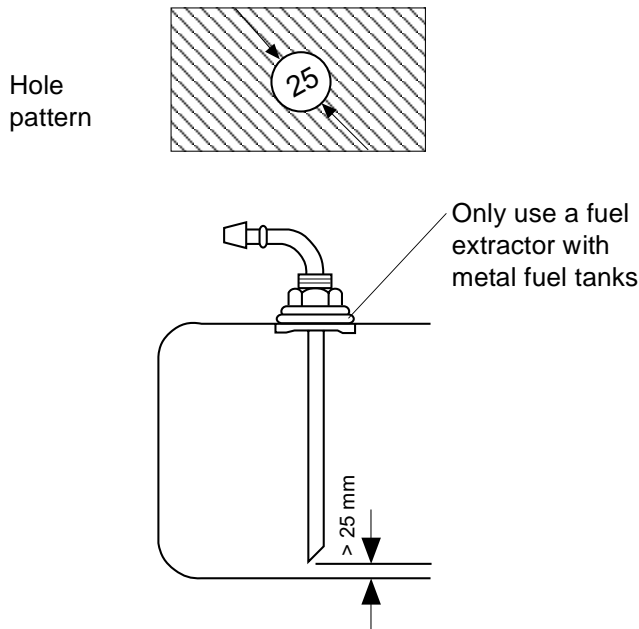

Fig. 803 Webasto fuel extractor

**NOTE**

The fitting must be made from metal!

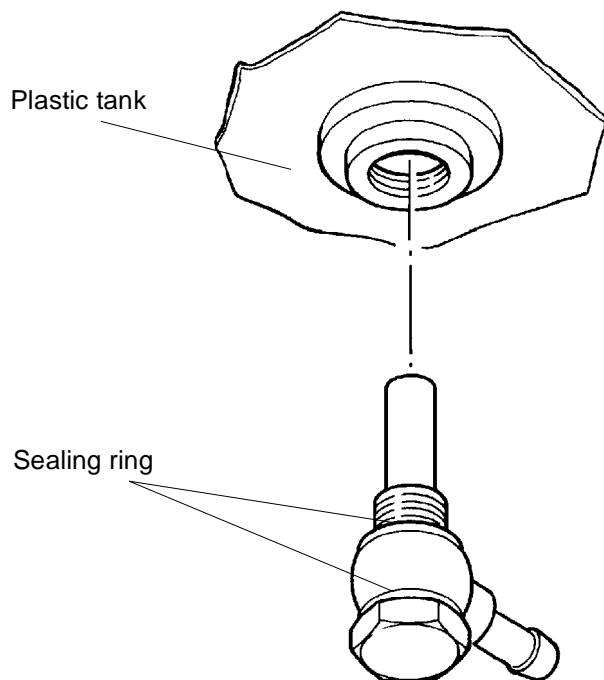

Fig. 804 Fuel extraction from the plastic tank (extraction through tank drain screw)

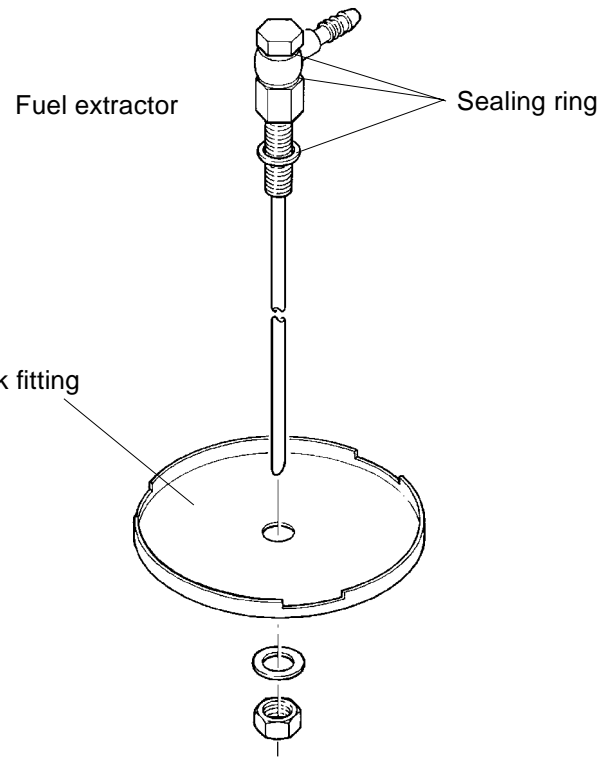

Fig. 805 Fuel extraction from the plastic tank (extraction through tank fitting)

**NOTE**

Deburr the cut on the fuel extractor after sawing it off and remove any metal chips

Vehicles with petrol engines

The heater must be integrated into the return line of fuel systems in carburettor and injection engines with a return line.

In carburettor engines without a return line the heater must be integrated into the fuel system in the supply line between the fuel tank and the vehicle pump.

**NOTE**

- A fuel feed line can normally be identified by the fact that a fuel filter is installed in it.
- If there is an evaporation tank in the vehicle's fuel system, the fuel must be extracted upstream of the evaporation tank.

Fuel may only be taken from the supply or return line using the special Webasto fuel extractor (Fig. 806). The fuel extractor must be fitted in such a way that any air or gas bubbles are automatically discharged towards the tank (Fig. 806). Air or gas bubbles may be produced in the vehicle's fuel line if there are leaks in the carburettor or vehicle fuel pump or if the ambient temperature is higher than the evaporation temperature of the fuel.

The fuel extractor should not be located near the engine, as gas bubbles may form in the lines on account of heat radiated from the engine. This may cause problems during combustion. When installing the heater in a vehicle with fuel injection system, it is important to establish whether the fuel pump is located inside or outside the tank. If the fuel pump is located inside the tank, fuel can only be extracted from the return line. In this case it must be ensured that the return line continues almost to the bottom of the tank and is not sealed by a non-return valve. If this is not the case the return line may be extended. If the fuel pump is installed outside the tank, the fuel connection may be made between the tank and the fuel pump.

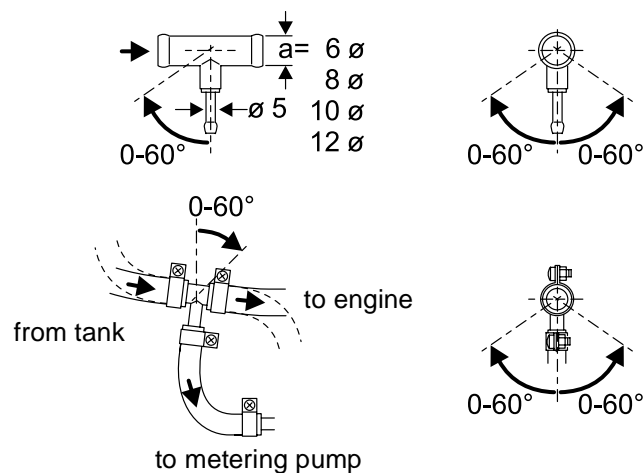

Fig. 806 Webasto fuel extractor

8.6.2.2 Fuel lines

Only steel, copper and plastic lines of plasticised, light and temperature-stabilized PA 11 or PA 12 (e.g. Mecanyl RWTL) pursuant to DIN 73378 may be used for the fuel lines.

**NOTE**

Cut Mecanyl lines without burr and do not crush them. Do not cut them with side-cutting pliers.

Since the lines normally cannot be routed with a constant rising gradient, the internal diameter must not be allowed to exceed a certain size. Air or gas bubbles will accumulate in lines with an internal diameter of more than 4 mm and these will cause malfunctions if the lines sag or are routed downwards. The diameters specified in Figs. 802 and 806 will ensure that bubbles do not form.

The lines should not be routed downwards from the metering pump to the heater.

Unsupported fuel lines must be secured to prevent them sagging. They must be installed in such a way that they cannot be damaged by flying road chippings and high temperatures (exhaust line).

The fuel lines must be secure at the connections using hose clips to prevent their slipping.

**Connecting two pipes with a hose**

The correct procedure for connecting fuel lines with hosing is shown in Fig. 807.

**NOTE**

Ensure that there are no leaks.

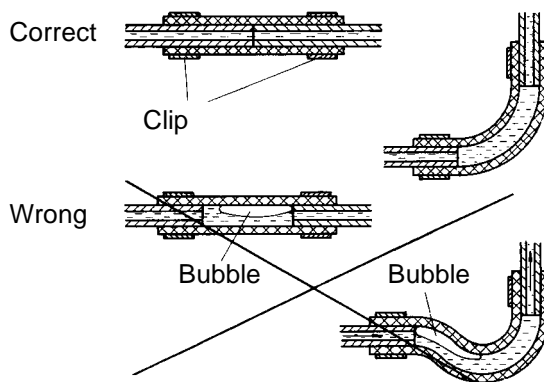
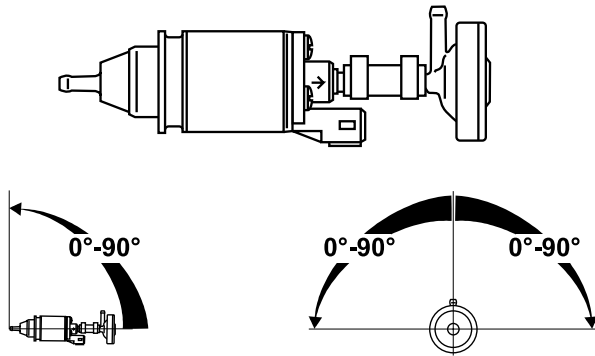

Fig. 807 Pipe/hose connection

**8.6.3 Metering pump with damper**

The metering pump is a combined delivery, metering and shut-off system and is subject to certain installation criteria (Figs. 802 and 808).



12 volts and 24 volts – petrol and diesel DP2

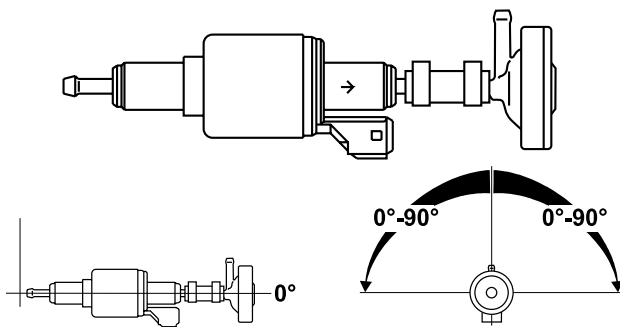

12 volts and 24 volts – diesel DP 30.2 only

**Horizontal installation position**

Fig. 808 Metering pump, installation position and attachment

**8.6.3.1 Installation position**

Before installing the metering pump, ensure that the maximum pressure occurring at the pickup point is less than 0.2 bar

It is advisable to install the metering pump in a cool place. The maximum ambient temperature must not exceed +20 °C for petrol and +40 °C for diesel at any time during operation.

The metering pump and fuel lines must not be installed within range of the radiated heat from hot vehicle parts. A heat shield must be used if necessary.

The pump should ideally be installed near the tank.

**8.6.3.2 Installation and attachment**

The metering pump must be secured with a vibration-damping mounting. Its installation position is limited as shown in Fig. 808 in order to ensure effective automatic bleeding.

**8.6.4 Fuel filter**

Only a Webasto filter, order no. 487 171, is allowed to be used if the fuel is expected to be contaminated. Install vertically if possible, however at least horizontally.

**NOTE**

Note the installation position and direction of flow.

**8.6.5 Combustion air supply**

Under no circumstances may the combustion air be taken from areas occupied by people. The combustion air intake opening must not point in the direction of travel. It must be located so that it cannot become clogged with dirt or snow and cannot suck in splashing water.

The combustion air intake line (internal diameter at least 30 mm) may be 0.5 m to 5 m long with several bends totalling 360°. Minimum bending radius is 45 mm.

The combustion air inlet must not be routed above the exhaust outlet.

**NOTE**

If the combustion air intake line cannot be installed so that it slopes downwards, a water drain hole (with a diameter of 4 mm) is to be made at its lowest point.

If the heater is installed in a general installation space near the vehicle's fuel tank, the combustion air must be taken in from the outside and the exhaust fumes discharged into the atmosphere. The openings must be splash-proof.

A ventilation opening measuring at least 6 cm<sup>2</sup> is required if the heater is installed in an enclosed box. The size of the ventilation opening must be increased accordingly if the temperature in the box exceeds the permitted ambient temperature of the heater (see Technical data).

### 8.6.6 Exhaust line

The exhaust line (internal diameter 38 mm) can be installed with a length of 0.5 m to 5 m and several bends (360° altogether, minimum bending radius 85 mm). The exhaust muffler is essential and must be installed near the heater.

An attachment is required no further than 150 mm from the end of the exhaust pipe to ensure that the angle of  $90^\circ \pm 10^\circ$  is achieved.

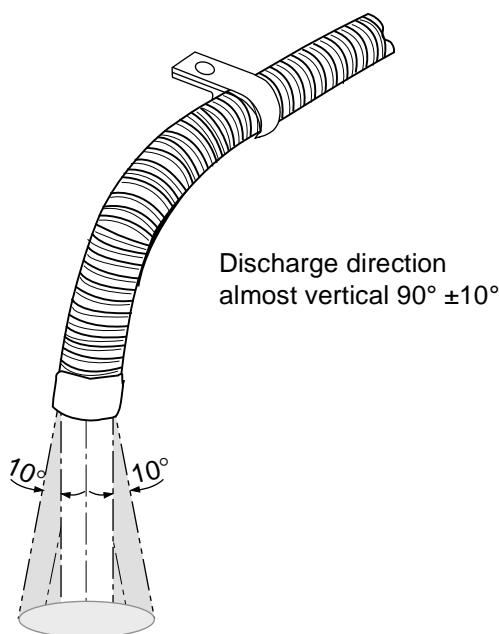

Fig. 809 Exhaust pipe opening, installation position

The opening of the exhaust pipe must not point towards the front of the vehicle (see Figure 809).

The exhaust pipe opening must be located so that it cannot become clogged with snow and mud.

Rigid pipes of unalloyed or alloyed steel with a minimum wall thickness of 1.0 mm or flexible piping of alloyed steel only must be used as the exhaust line. The exhaust pipe is secured to the heater using a clamping collar, for example. See the statutory regulations for other requirements.

Only for ADR: The statutory regulation of ADR (Accord européen relatif au transport international des marchandises dangereuses par route) governing the routing of the exhaust line, part 9 para. 9.2.4.7, must be adhered to.

## 8.7 Removal and installation

### CAUTION

When the heater is installed, only the following dismantling or removal procedures are permitted providing the upper cover cap is accessible and can be removed, and there is sufficient room for removal:

- Changing the circulating pump
- Changing the temperature limiter
- Changing the temperature sensor
- Changing the combustion air fan
- Changing the control unit (Thermo 90 S/ Thermo 90 ST)

### 8.7.1 Heater, removal and installation

#### 8.7.1.1 Removal

1. Disconnect the battery.

#### NOTE

Only disconnect plug connectors X12 and X13 on the control unit in the Thermo 90 S heater with the control unit flange-mounted on the combustion air fan.

2. Remove the upper cover cap.
3. Disconnect the wiring harness plug from the heater.
4. Disconnect the connection for the combustion air inlet on the heater.
5. Unfasten the hose clips and pull the coolant hoses off the heater.
6. Disconnect the connections for the combustion air inlet and exhaust outlet on the heater.
7. Remove three screws and washers from the heater holder.
8. Remove the heater.

#### 8.7.1.2 Installation

1. Position the heater in its installation position and screw in 3 screws with washers to attach it.
2. Connect the coolant hoses and secure with hose clips. Tighten the hose clips to 5 Nm.
3. Secure the connection for the combustion air inlet on the heater.
4. Secure the connections for the combustion air inlet and exhaust outlet on the heater.

#### NOTE

Only reconnect plug connectors X12 and X13 on the control unit in the Thermo 90 S heater with the control unit flange-mounted on the combustion air fan.

5. Connect the wiring harness plug to the heater.
6. Put on the top cover cap and lock it in place.
7. Connect the battery.
8. Bleed the fuel supply system.
9. Bleed the coolant circuit.

**8.7.2 Changing the circulating pump****NOTE**

The process for changing the circulating pump is the same irrespective of whether the heater is installed or removed.

Change as described in 9.2.2.

**8.7.3 Changing the temperature limiter****NOTE**

The process for changing the temperature limiter is the same irrespective of whether the heater is installed or removed.

Change as described in 9.2.3.

**8.7.4 Changing the temperature sensor****NOTE**

The process for changing the temperature sensor is the same irrespective of whether the heater is installed or removed.

Change as described in 9.2.4.

**8.7.5 Changing the combustion air fan****NOTE**

The process for changing the combustion air fan is the same irrespective of whether the heater is installed or removed.

Change as described in 9.2.5.

**8.8 Start-up**

After you have installed the heater, bleed the coolant circuit and the fuel supply system carefully. Comply with the instructions given by the vehicle manufacturer when doing this. During the trial run, check all coolant and fuel connections for leaks and to ensure that they are secure. If the heater suffers a fault during operation, the fault must be located and remedied (see section 5).

## **9 Repair**

### **9.1 General**

This section describes the repair work which is permitted on the heater when it has been removed. Any further dismantling will invalidate the warranty.

Only use the spare parts from the appropriate spare parts kits for assembling the heater.

#### **9.1.1 Work on stripped-down components**

##### **CAUTION**

All seal elements between the dismantled components must be removed and new ones fitted.

#### **9.1.1.1 Cleaning**

- Clean all stripped down components.

#### **9.1.1.2 Visual inspection**

- Check all components for damage (cracks, deformation, wear, etc.) and fit new ones if necessary.
- Inspect the plugs and cables for corrosion, loose contacts, crimping faults, etc. and repair them if necessary.
- Check plug contacts for signs of corrosion and to ensure they are secure. Repair them if necessary.

9.2 Dismantling and assembling

9.2.1 Electrical connections (Thermo 90 S)

9.2.1.1 Disconnecting the electrical connections (plug connector X1)

**NOTE**

All electrical connections are grouped together in the plug. Before removing a component, first disconnect the corresponding electrical connections.

In the Thermo 90 S heater with flange-mounted combustion air fan, disconnect plug X1 on the heater and plug connector X12 on the control unit. Reconnect them after restoring the electrical connections.

1. Remove the upper cover cap from the heater.
2. Use the removing tool (hook part) to pull the locking wedge out of the plug.
3. Use the removing tool (screwdriver part) to press the corresponding locking lug, keep it pressed and pull the cable out of the plug.

9.2.1.2 Making the electrical connections

1. Push the cable into the corresponding contact hole until it locks.
2. Use the removing tool (screwdriver part) to insert the locking wedge in the plug and press in until it locks.
3. Put on the upper cover cap.

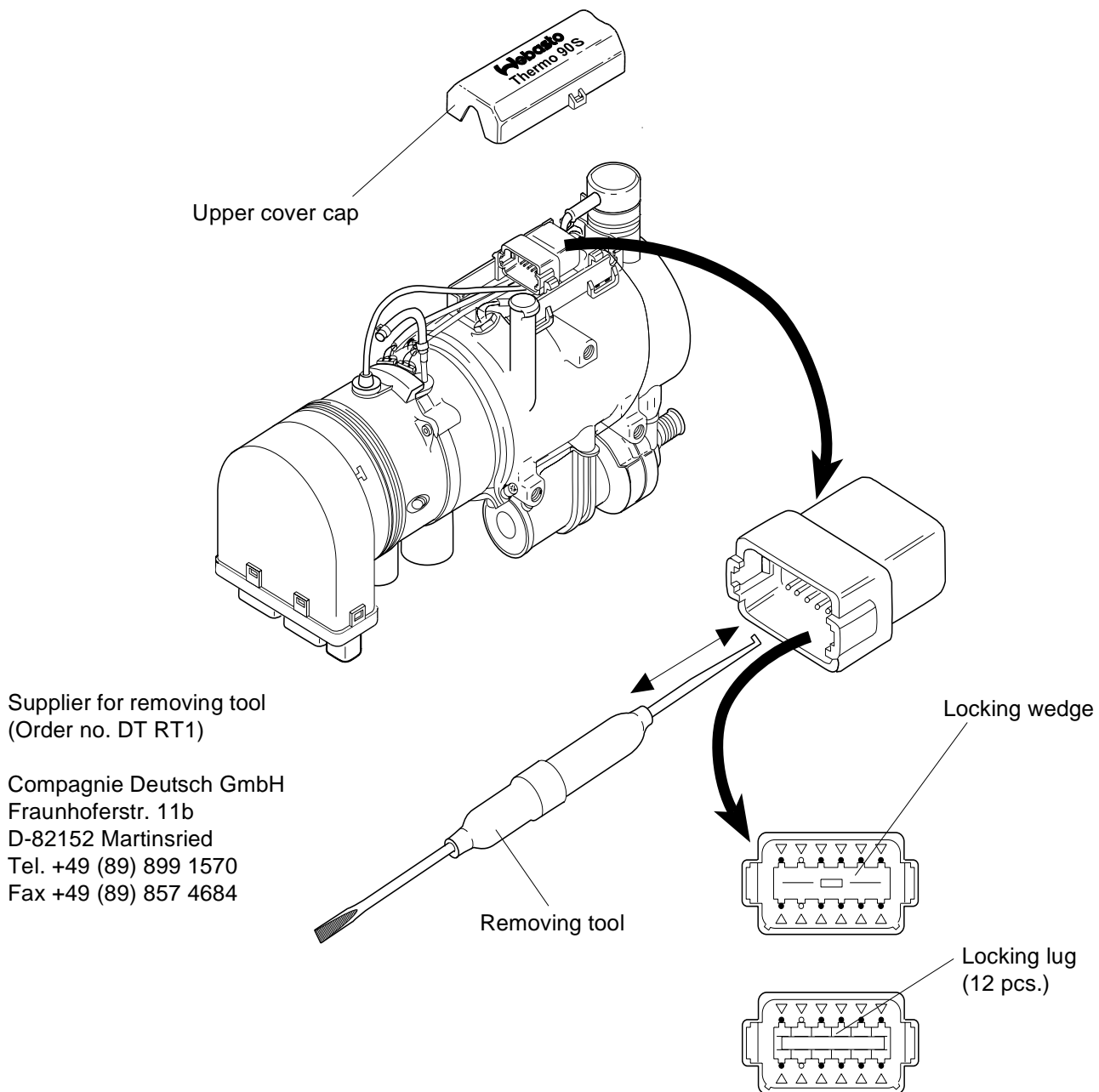

Supplier for removing tool  
(Order no. DT RT1)

Compagnie Deutsch GmbH  
Fraunhoferstr. 11b  
D-82152 Martinsried  
Tel. +49 (89) 899 1570  
Fax +49 (89) 857 4684

Fig. 901 Electrical connections (Thermo 90 S)

9.2.2 Changing the circulating pump

9.2.2.1 Removal

1. Remove the heater (see 8.7.1.1).
2. Disconnect the electrical connections (see 9.2.1.1).
3. Remove the screws (4, Fig. 902).
4. Remove the clip (3) and circulating pump (2).
5. Complete the work on stripped-down components (see 9.1.1).

9.2.2.2 Installation

1. Apply acid-free grease (Vaseline) to the sealing ring (1, Fig. 902).
2. Place the circulating pump (2, Fig. 902) in the assembly position and attach with the clip (3) and screws (4).
3. Tighten the screws (4) to 3 Nm  $\pm$ 10%.
4. Connect the electrical connections (see 9.2.1.2).
5. Install the heater (see 8.7.1.2).

**NOTE**

A Thermo 90 ST heater is shown. In the Thermo 90 S heater, the control unit can also be arranged on the combustion air fan without having any effect on changing the circulating pump.

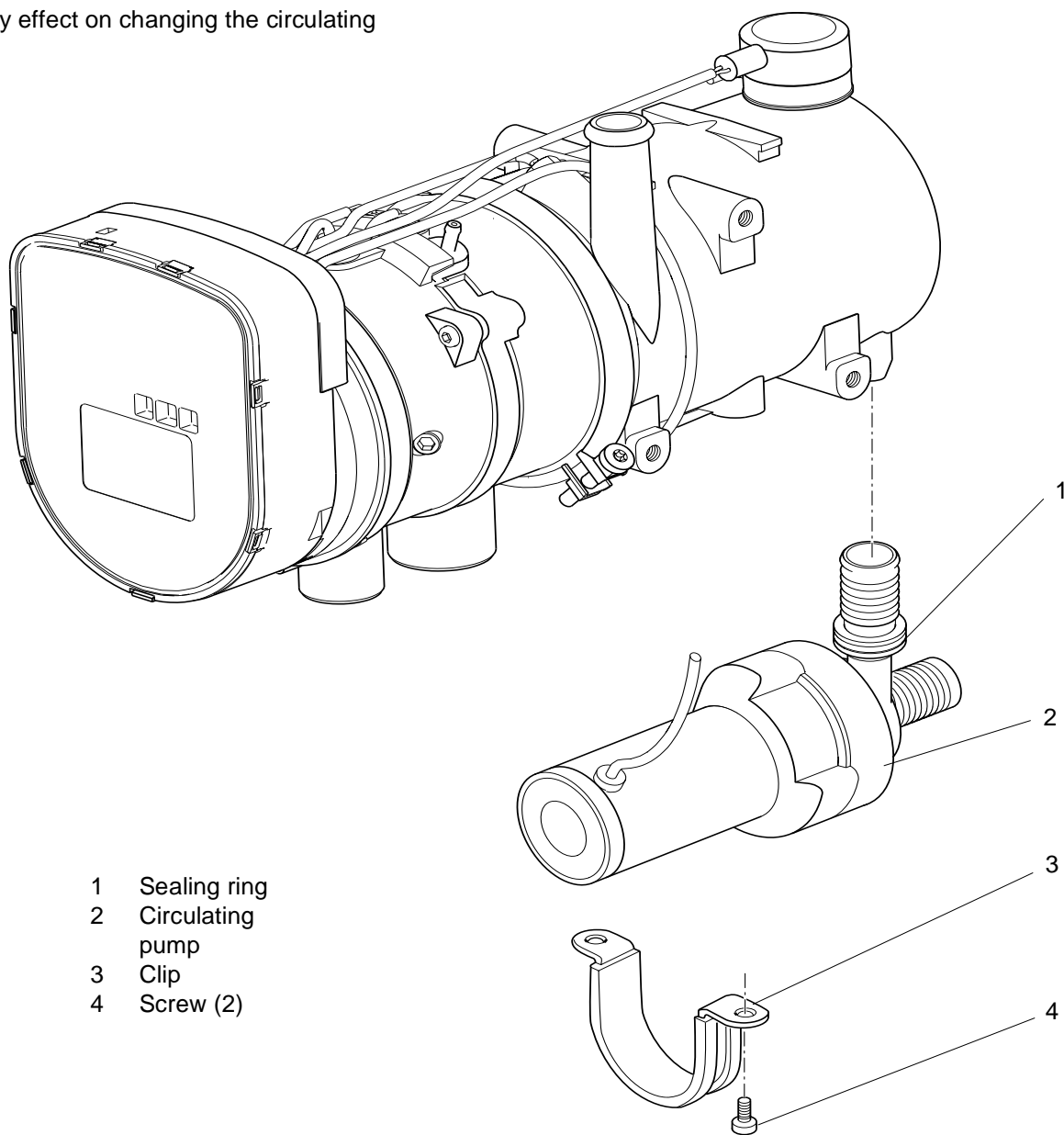

- 1 Sealing ring
- 2 Circulating pump
- 3 Clip
- 4 Screw (2)

Fig. 902 Changing the circulating pump

**9.2.3 Changing the temperature limiter****9.2.3.1 Removal****NOTE**

The temperature limiter only has to be removed if it is being replaced with a new one.  
The function must be checked in the installed condition.

1. Remove the heater (see 8.7.1.1).
2. Disconnect the electrical connections (see 9.2.1.1).
3. Remove the clip (2, Fig. 903) and pull off the protective cap (1).
4. Use a screwdriver to lever off the retaining spring and remove the temperature limiter (3).
5. Complete the work on stripped-down components (see 9.1.1).

**NOTE**

It is essential to fit a new temperature limiter to replace a removed one!

**9.2.3.2 Installation****CAUTION**

Incorrect installation will cause the heat exchanger to melt.

1. Insert the new temperature limiter (3, Fig. 903) into the heat exchanger (4) and press in the retaining spring.

**NOTE**

You must be able to hear and feel the spring clip into the groove. Only then is the temperature limiter in the correct installation position.

If you do not hear and feel the spring clip in:

- Clean the contact surface of the temperature limiter on the heat exchanger
  - Clean the groove in the heat exchanger
  - Ensure that the detent lugs are present on both sides of the spring. Fit a new temperature limiter if necessary.
2. Put on the protective cap (1) and secure it with the clip (2).
  3. Tighten the clip to 1 Nm  $\pm$ 10%.
  4. Connect the electrical connections (see 9.2.1.2).
  5. Install the heater (see 8.7.1.2).

**9.2.4 Changing the temperature sensor****9.2.4.1 Removal**

1. Remove the heater (see 8.7.1.1).
2. Disconnect the electrical connections (see 9.2.1.1).

**WARNING**

Leaking hot coolant can cause burns.

3. Unscrew and remove the temperature sensor (6, Fig. 903) and remove it together with the round sealing ring (5).
4. Complete the work on stripped-down components (see 9.1.1).

**9.2.4.2 Installation**

1. Apply acid-free grease (Vaseline) to the round sealing ring (5, Fig. 904).
2. Fit the temperature sensor (6) with the round sealing ring (5) and screw it into the heat exchanger (4). Tighten to 1.5 Nm  $\pm$ 10%.
3. Connect the electrical connections (see 9.2.1.2).
4. Install the heater (see 8.7.1.2).

**NOTE**

A Thermo 90 ST heater is shown. In the Thermo 90 S heater, the control unit can also be arranged on the combustion air fan without having any effect on changing the temperature sensor.

- 1 Protective cap
- 2 Clip
- 3 Temperature limiter
- 4 Heat exchanger
- 5 Round sealing ring
- 6 Temperature sensor

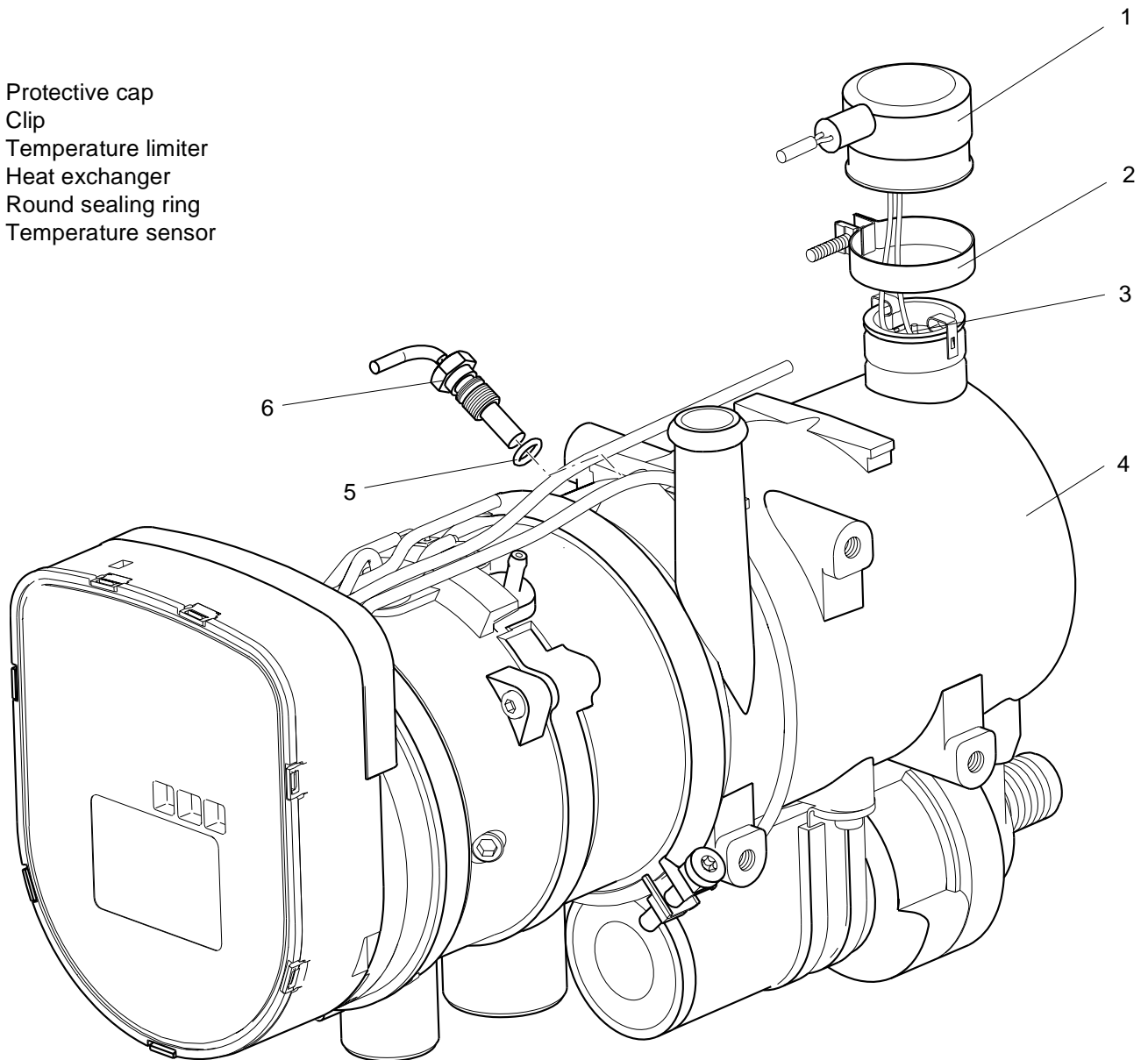

Fig. 903 Changing the temperature limiter and temperature sensor

## 9.2.5 Changing the combustion air fan

### 9.2.5.1 Removal

1. Remove the heater (see 8.7.1.1).
2. Disconnect the electrical connections (see 9.2.1.1).
3. Remove the screws (2, Fig. 904).
4. Pull the combustion air fan (1) off the burner head (4) and remove together with the shaped sealing ring (3).

**NOTE**

Remove the control unit if necessary from the Thermo 90 S/Thermo 90 ST heater with flange-mounted control unit.

5. Complete the work on stripped-down components (see 9.1.1).

### 9.2.5.2 Fitting

**NOTE**

Insert the shaped seal (3, Fig. 904) correctly and grease it (e.g. with Vaseline). Take care not to squash it.

1. Fit the new shaped sealing ring (3) onto the combustion air fan (1). Bring the fan into the assembly position and secure it with screws (2).
2. Tighten the screws (2) to 3 Nm  $\pm$ 10%.

**NOTE**

Install the control unit if necessary on the Thermo 90 S/Thermo 90 ST heater with flange-mounted control unit.

3. Connect the electrical connections (see 9.2.1.2).
4. Install the heater (see 8.7.1.2).

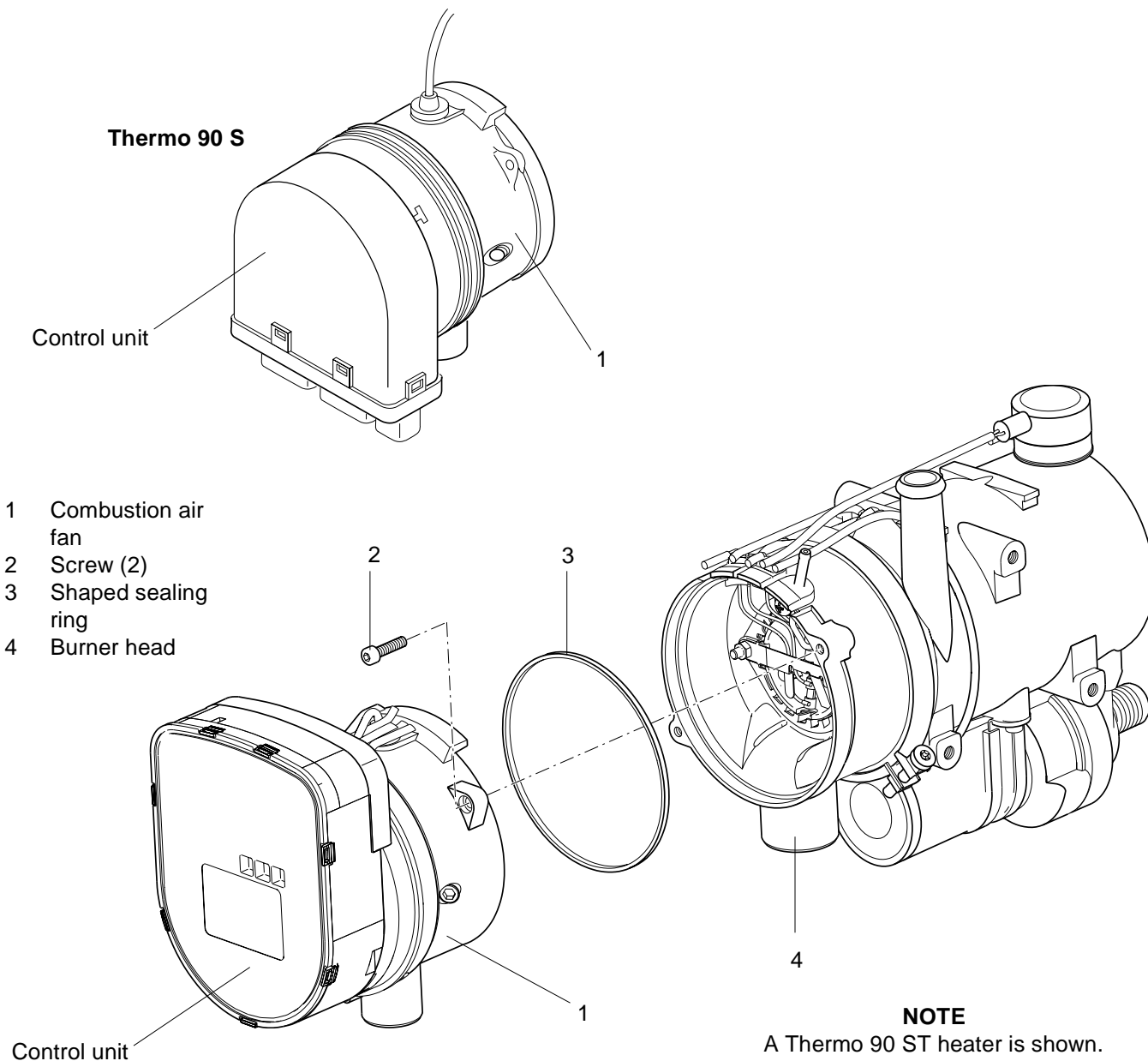

Fig. 904 Changing the combustion air fan

## 9.2.6 Changing the burner, flame monitor and glow plug

### 9.2.6.1 Removal

1. Remove the heater (see 8.7.1.1).
2. Remove the combustion air fan (see 9.2.5.1).
3. Remove the screw (5, Fig. 905) and washer (4).
4. Remove the nuts (10) and pull off the bar (8).
5. Pull the grommets (11 and 12) out of the slots in the housing of the combustion pipe (3).
6. Pull the grommet (13) and burner (1) out of the burner head and remove with the swirl orifice (2).
7. Pull the flame monitor (7) and glow plug (6) from the burner (1) and remove.
8. Perform a visual check for assessing the burner (see 5.3).
9. Complete the work on stripped-down components (see 9.1.1).

### 9.2.6.2 Installation

1. Place the swirl orifice (2, Fig. 905) onto the burner (1).
2. Carefully insert the flame monitor (7) and glow plug (6) into the burner up to the stop and push the grommets (11 and 12) into the slots in the housing of the burner pipe (3).
3. Insert the burner (1) and grommet (13) into the burner head (3).

**CAUTION**  
During the following procedure, make sure that the cables of the flame monitor (7) and the glow plug (6) are routed as shown in the figure.

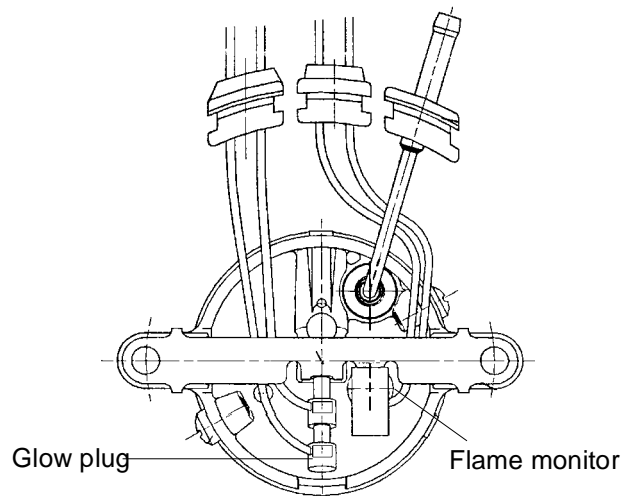

4. Push the insulation (9) onto the bar (8) and bring the bar into the assembly position.

**NOTE**  
Route the cable of the flame monitor and the glow plug as shown in the figure!

5. Secure the bar (8) using the nuts (10). Tighten the nuts to 3 Nm  $\pm$ 10%.
6. Secure the fuel line using the screw (5) and washer (4). Tighten the screw to 3 Nm  $\pm$ 10%.
7. Fit the combustion air fan (see 9.2.5.2).
8. Connect the electrical connections (see 9.2.1.2).
9. Install the heater (see 8.7.1.2).

**NOTE**

A Thermo 90 ST heater is shown.  
The figure can also be used for the  
Thermo 90 S heater.

- 1 Burner
- 2 Swirl orifice
- 3 Burner head
- 4 Washer
- 5 Screw
- 6 Glow plug
- 7 Flame monitor
- 8 Bar
- 9 Insulation
- 10 Nut (2)
- 11 Grommet
- 12 Grommet
- 13 Grommet

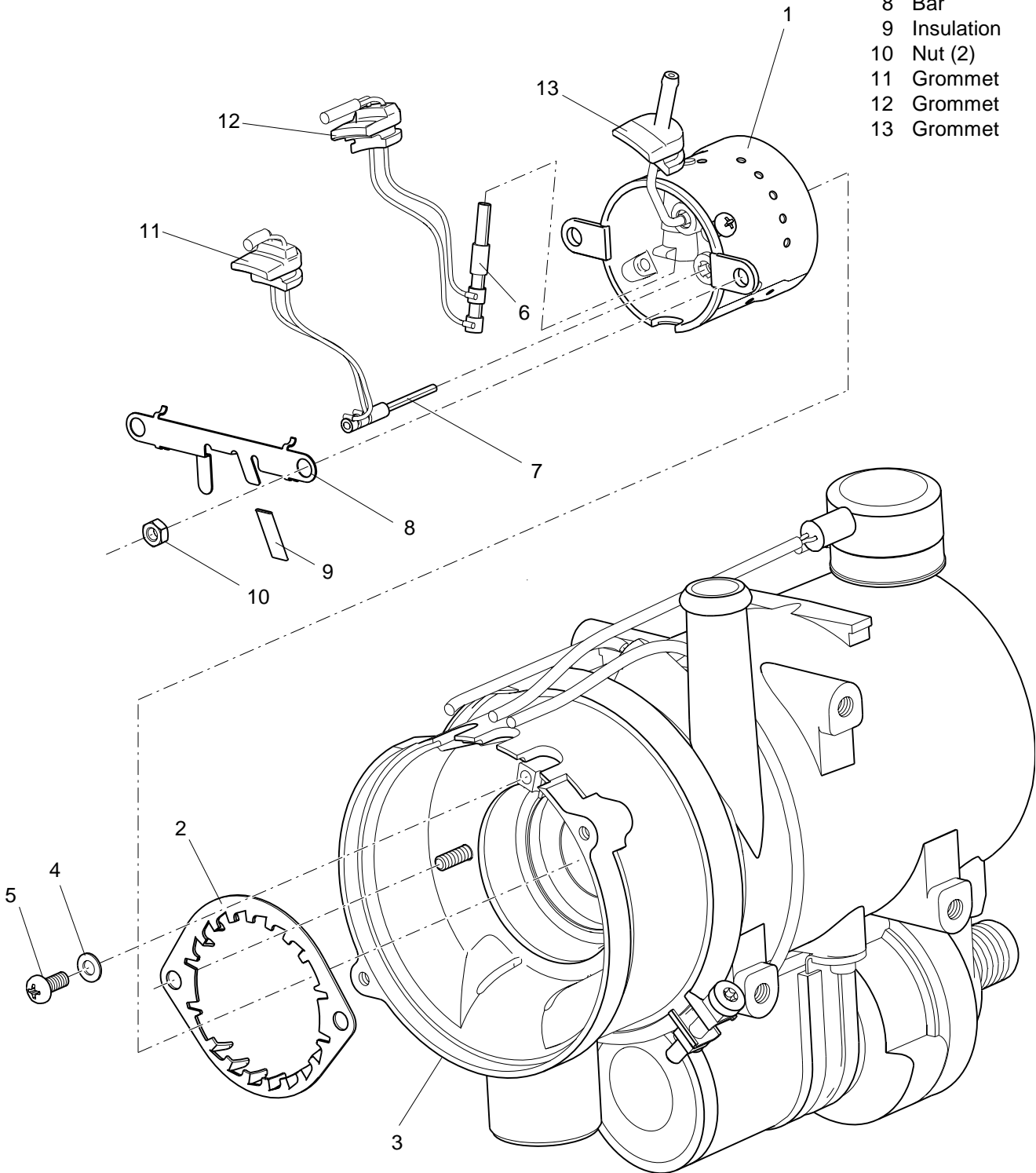

Fig. 905 Changing the burner, flame monitor and glow plug

9.2.7 Changing the burner head

9.2.7.1 Removal

1. Remove the heater (see 8.7.1.1).
2. Remove the combustion air fan (see 9.2.5.1).
3. Remove the burner, flame monitor and glow plug (see 9.2.6.1).
4. Remove the mounting screw of the V-clamping collar (2, Fig. 906) and pull off the clamping collar.
5. Pull out and remove the burner head (1) from the heat exchanger (3).
6. Complete the work on stripped-down components (see 9.1.1).

**NOTE**

A Thermo 90 ST heater is shown. The figure can also be used for the Thermo 90 S heater.

9.2.7.2 Installation

**NOTE**

The burner head and exhaust outlet port can also be aligned during installation in the vehicle.

1. Guide the burner head (1, Fig. 906) into the heat exchanger (3), align it if necessary and secure with the V-clamping collar (2).
2. If necessary, tighten the mounting screw of the V-clamping collar to 3 Nm  $\pm$ 10%.
3. Install the burner, flame monitor and glow plug (see 9.2.6.2).
4. Fit the combustion air fan (see 9.2.5.2).
5. Install the heater (see 8.7.1.2).

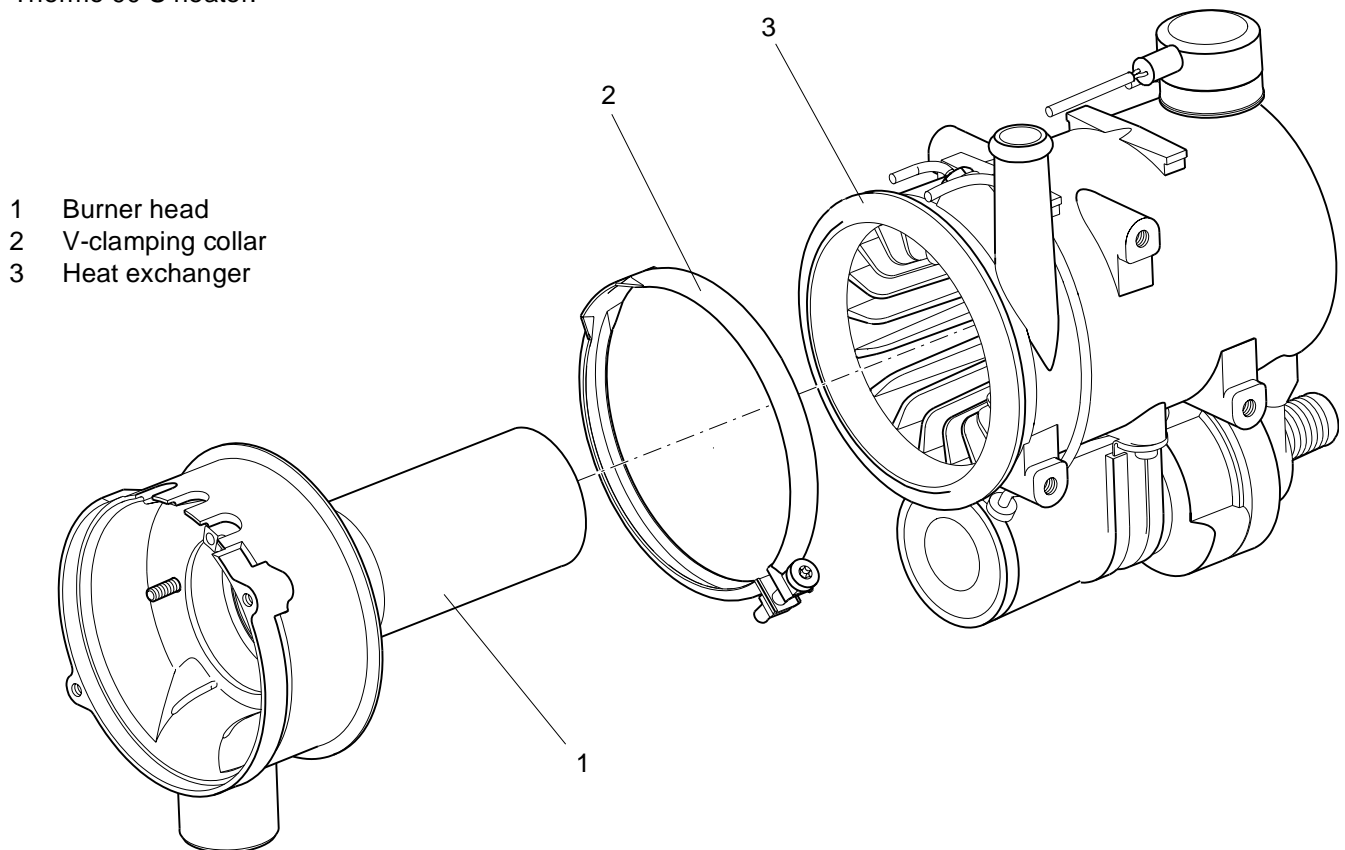

Fig. 906 Changing the burner head

**9.2.8 Changing the heat exchanger****9.2.8.1 Removal**

1. Remove the heater (see 8.7.1.1).
2. Remove the circulating pump (see 9.2.2.1).
3. Remove the temperature limiter (see 9.2.3.1).
4. Remove the temperature sensor (see 9.2.4.1).
5. Remove the combustion air fan (see 9.2.5.1).
6. Remove the burner, flame monitor and glow plug (see 9.2.6.1).
7. Remove the burner head (see 9.2.7.1).
8. Remove the plug and connector housing.
9. Complete the work on stripped-down components (see 9.1.1).

**9.2.8.2 Installation**

1. Clip the connector housing onto the heat exchanger and insert the plug into the connector housing.
2. Install the burner head (see 9.2.7.2).
3. Install the burner, flame monitor and glow plug (see 9.2.6.2).
4. Fit the combustion air fan (see 9.2.5.2).
5. Install the temperature sensor (see 9.2.4.2).
6. Install the temperature limiter (see 9.2.3.2).
7. Fit the circulating pump (see 9.2.2.2).
8. Install the heater (see 8.7.1.2).

## **10 Packing / Storage and Shipment**

### **10.1 General**

If the heater or its components are sent to Webasto Thermosysteme GmbH for testing or repair, it must be cleaned and packed in such a way that it is protected against damage during handling, transport and storage.

#### **CAUTION**

Fully drain a complete heater before sending it back. Make sure that no fuel or coolant can leak out during packing and/or shipment.

Seal the coolant ports with dummy plugs.

The ambient temperatures listed in section 4 must not be exceeded during storage.

